

# GENESIS INTERNATIONAL, INC.

## WALK-IN MONITOR COOLER ALARMING SYSTEM WITH LEAK DETECTION (WIM-L)



**WALK-IN MONITOR (WIM-L)**

Kit Part # 88-0324-00 with Room Temperature Sensor

The Wizard Single Walk-in Cooler Monitoring System with Leak Detection (WIM-L) is an ETL approved monitor and was designed to incorporate most of the functions necessary to monitor the evaporators of a walk-in cooler and freezer of a supermarket, convenience store or restaurant into a compact, simple to install package. The Control utilizes the latest microprocessor technology with two row 16 character LCD back-lighted display. Plain English menu driven user interface is easy to understand and manipulate. It is equipped with a real time clock and a 5 day power loss backup. The control has as standard, an onboard 95db buzzer and a red light that will notify of an alarm. The unit is standard with 6 SPDT system alarm relays (One Silence-able, One Non Silence-able System alarm and four refrigerant leak relays for 2 discrete alarm levels). A single Wizard Walk-in Monitoring System can replace the following items for a complete Walk-In unit:

- Temperature Monitoring and Alarming
- Door Opening Alarm
- Entrapment Alarm
- Refrigerant Gas Leak Monitor and Alarm

Model #	Nema/IP Rating	Size Inches (mm)	Electrical Category	Pollution Protection
WIM-L	1	7.25 x 8.0 x 3 (184 x 203 x 76)	II	2

**POWER** 100 or 220 VAC, 50/60 Hz, 1.0 Amps

**INPUTS** One of the following:  
 Thermistor Temperature Sensor  
 Door Ajar Magnetic Contact Switch  
 Entrapment Push button switch

**OPTIONAL INPUTS**  
 Sherlock Refrigerant Sensor CMOS,  
 Electro-Chemical or Infrared (IR)

**OUTPUTS** 6 SPDT, 1 Form C Relays, 250 VAC, 5.0 Amp fuses and spike suppressors  
 Optional 4-20mA Analog Signal for Temperature Sensor(s)  
 (WIM-L-AO only)

**OPERATING TEMPERATURE**  
*Monitor* 45°F - 99°F  
*Temperature Sensor* -50°F - 150°F

**OPERATING HUMIDITY**  
 30% - 90% RH, non-condensing

**ALARMS** System Alarms (2 relays)  
 DoorAjar, Entrapment  
 Low Temperature, High Temperature  
 Refrigerant Gas Leak Alarm  
 Two alarm levels (2 SPDT Relays per level)

**DISPLAY** 2 lines by 16 characters  
 Alphanumeric LCD with back light  
 Alarm Indication LED -- indicates active alarm

**KEYPAD** 5 tactile key switches  
 Scroll up, Scroll down, Select/Change, Exit, Alarm Silence/Clear

**ALARM INDICATORS**  
**LCD DISPLAY** Cause of Alarming  
**BUZZER** piezo-electric, 90db @10ft, silenceable  
**FRONT PANEL LED LIGHT** Flashing red light when Control is in alarm  
**STROBE LIGHT (Optional)** Mounted on top of the housing, activates during any alarm condition.

**LISTINGS**  
 ETL, Conforms to UL Std. 61010-1  
 Certified to CAN/CSA, C22.2 Std. No. 61010-1

**WARRANTY** 15 Month Limited

WIM-L 10-11-19

**Real Time Clock with power loss backup** - The built-in electronic time clock is used for time-stamp of alarm logs. The time clock has ninety nine year calendar for automatic day light saving change over. The clock maintains its setting for up to 5 days without power.

**Software Access "Passcode"** - The WIM-L is passcode protected. No operating parameters can be changed without unlocking the Control. User passcode can be changed by supervisor.

**Enclosure** - The WIM-L comes in a metal, NEMA 1 enclosure suitable for mounting on the wall outside of the Walk-in Cooler.

**Four Key Menu System** - Consistent menu structure using only four keys. Operating parameters can be accessed and changed easily.

**Alarm History logs** - Last ten alarm logs are maintained for reviewing at any time. Each log has its own time stamp along with alarm reading.

**Temperature Alarming** - The WIM-L can monitor the temperature in a single zone (room). The WIM-L will activate its audible visual alarm and the System Alarm Relays based upon the following alarm conditions:

**High Alarm** . The room temperature must exceed the High Alarm Limit for a time period equal to or longer than the High Temp Alarm delay.

**Low Alarm** . The room temperature must be below the

Low Alarm Limit for a time period equal to or longer than the Low Temp Alarm delay.

**Door Ajar Alarming** - The WIM-L will activate its audible visual alarm and the System Alarm Relays if the monitored door is opened (Door Switch is closed) for more than the Door Open Alarm Delay time. When the door is opened, the display shows the duration of the door opening in hours and minutes. To monitor more than one door, connect all door switches in parallel. **(Genesis #28-0117-00)**

**Entrapment Alarming** - The WIM-L will activate its audible visual alarm and the System Alarm Relays if a normally closed Entrapment Push Button is momentarily pushed to open. To monitor more than one Entrapment Push Buttons, connect all the buttons in series. This alarm is always active. To disable this alarm, short the two input connectors together with a piece of bare copper wire. **(Genesis #28-0123-00)**

**Refrigeration Leak Monitoring** - With the addition of a SHERLOCK Refrigerant gas sensor, the WIM-L makes any refrigerated room or freezer room ASHRAE 15-2019 and Mechanical Code Compliant. The sensor can be gas specific Infrared (IR), Solid State CMOS or Electro-Chemical. The Leak detection feature adds 4 SPDT alarm relays for two leak alarm levels with 1 silence-able and 1 non silence-able relay for each alarm level. The WIM-L can remotely notify systems and isolate the evaporator coil if a leak level exceeds safety limits.

## WIM-L TYPICAL WIRING DIAGRAM

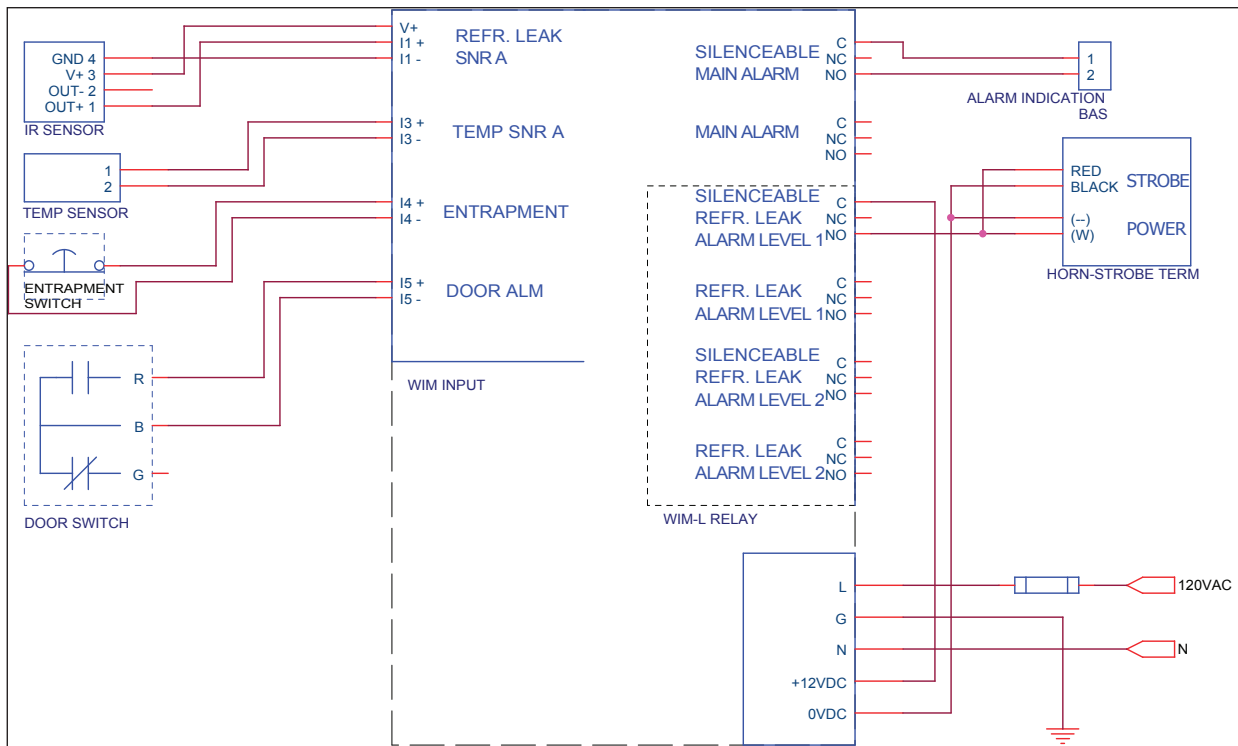

# GENESIS INTERNATIONAL, INC.

1040 Fox Chase Industrial Dr  
Arnold, MO 63010

Email: mail@genesis-international.com

Tel: 636-282-0011

Fax: 636-282-2722

Web: www.genesis-international.com