

GENESIS INTERNATIONAL, INC.

WALK-IN SINGLE ZONE DEFROST CONTROL & ALARMING SYSTEM (WIC)

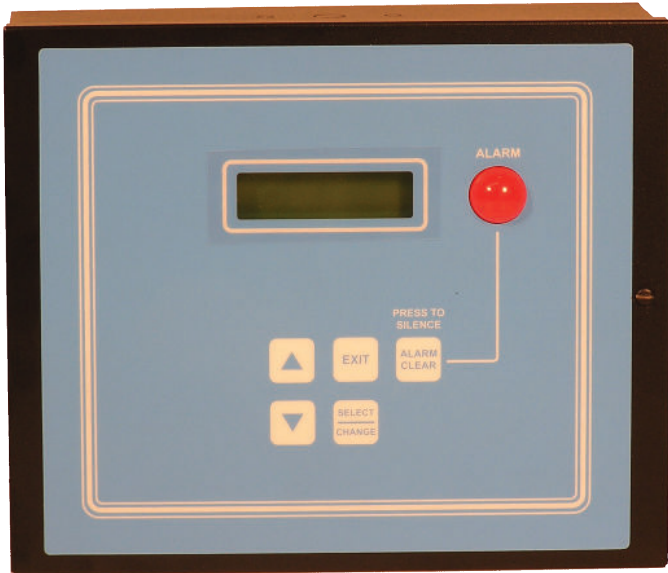

WALK-IN CONTROL (WIC)
Part Number 88-0353

The Wizard Single Zone (WIC) Cooler Control System was designed to incorporate most of the control functions necessary to monitor and control the evaporators of a walk-in cooler and freezer of a supermarket, convenience store or restaurant into a compact, simple to install package. The WIC utilizes the latest microprocessor technology with two row 16 character LCD back-lighted display. Plain English menu driven user interface is easy to understand and manipulate. It is equipped with a real time clock with a 5 day power loss backup. The control has as standard, an onboard 95db buzzer and a red light that will notify of an alarm. The unit is standard with 4 SPDT relays. A single Control can replace the following items for a complete Walk-In unit:

**Temperature Monitor, Control & Alarm
Door Opening Alarm
Defrost Controller**

Model #	Nema/IP Rating	Size Inches (mm)	Electrical Category	Pollution Protection
WIC	1	7.25 x 8.0 x 3 (184 x 203 x 76)	II	2

- POWER** 25 - 250V AC, 50/60Hz, 1.0 Amp
- OPERATING TEMPERATURE** 45°F - 99°F
- OPERATING HUMIDITY** 30 - 90% RH, non-condensing
- DISPLAY** 2 lines by 16 characters, alphanumeric LCD with back light, Alarm Indication Light indicates active alarm
- KEYPAD** 5 tactile key switches
Scroll up, Scroll down, Select/Change, Exit, Alarm Silence/Clear
- INPUTS** Thermistor Temperature Sensor
Door Ajar Magnetic Contact Switch
Defrost Termination Switch/Sensor

Control, Fan, Defrost and Alarm Relays - These Relay Outputs are 1 Form C SPDT rated for 250 VAC and 3.15 Amp per circuit. Each relay circuit is fused with a slow blow fuse on the common leg. Outputs are screw terminal type.

CONTROL One (1) Liquid Solenoid Relay
One (1) Evaporator Fan Relay
One (1) Defrost Heater Relay

ALARMS One (1) System Alarm Relay
DoorAjar, Low & High Temperature

ALARM INDICATORS

LCD DISPLAY Cause of Alarming

BUZZER piezo-electric, 90db @10ft, silenceable

FRONT PANEL LED LIGHT Flashing red light when Control is in alarm

STROBE LIGHT (Optional) Mounted on top of the housing, activates during any alarm condition.

- LISTINGS** ETL, Conforms to UL Std. 3111-1
Certified to CAN/CSA
C22.2 Std. No. 1010.1



Real Time Clock with power loss backup - The built-in electronic time clock is used for time-stamp of alarm logs. The time clock has ninety nine year calendar for automatic day light saving change over. The clock maintains its setting for up to 5 days without power.

Software Access "Passcode" - The WIC is passcode protected. No operating parameters can be changed without unlocking the Control. User passcode can be changed by supervisor.

Enclosure - The WIC comes in a metal, NEMA 1 enclosure suitable for mounting on the wall outside of the Walk-in Cooler.

Four Key Menu System - Consistent menu structure using only four keys. Operating parameters can be accessed and changed easily.

Alarm History logs - Last ten alarm logs are maintained for reviewing at any time. Each log has its own time stamp along with alarm reading.

Standard Defrost Control - The WIC controls the Defrost of the evaporator coil, runs the Pump Down Cycle and Drip Cycle and One relay each for defrost, liquid solenoid, Evaporator Fan and Evaporator Heater.

Temperature Alarming - The WIC can monitor the temperature in a single zone (room). The WIC will activate its audible visual alarm and the System Alarm Relays based upon the following alarm conditions:

High Alarm . The room temperature must exceed the High Alarm Limit for a time period equal to or longer than the High Temp Alarm delay.

Low Alarm . The room temperature must be below the Low Alarm Limit for a time period equal to or longer than the Low Temp Alarm delay.

Door Ajar Alarming - The WIC will activate its System Alarm Relay if the monitored door is opened (Door Switch is closed) for more than the Door Open Alarm Delay time. When the door is opened, the display shows the duration of the door opening in hours and minutes. To monitor more than one door, connect all door switches in parallel. (Genesis #28-0117)

WIC TYPICAL WIRING DIAGRAM

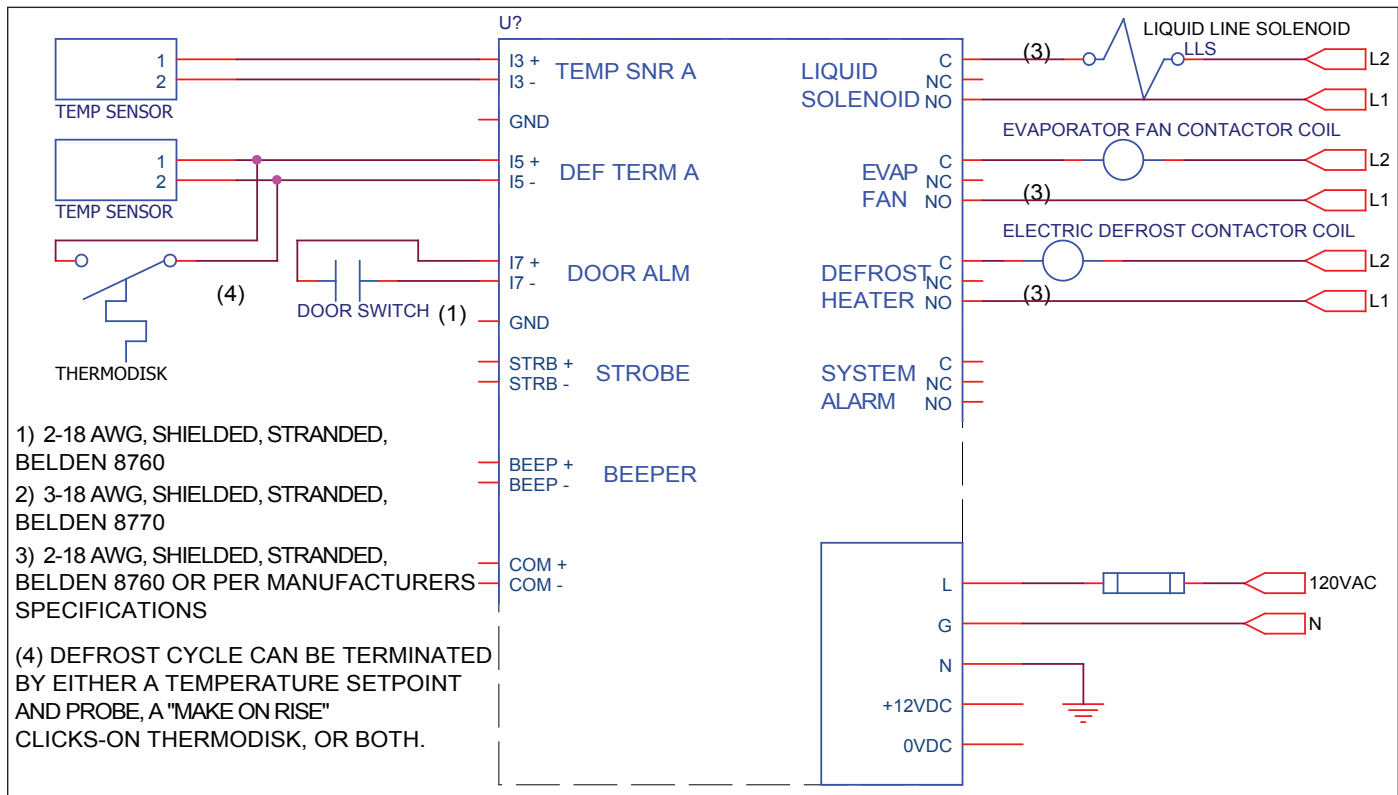

GENESIS INTERNATIONAL, INC.

1040 Fox Chase Industrial Dr
 Arnold, MO 63010
 Email: mail@genesis-international.com

Tel: 636-282-0011
 Fax: 636-282-2722
 Web: www.genesis-international.com