

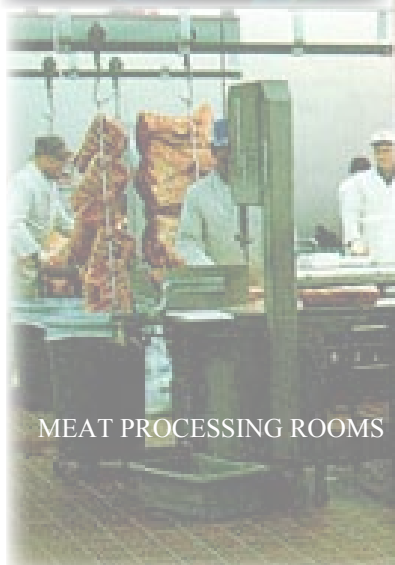

PRODUCE STORAGE



PRODUCE STORAGE



MEAT PROCESSING ROOMS



COLD STORAGE



Wizard

Industrial Refrigeration Control



SEAFOOD STORAGE



WAREHOUSES

OVERVIEW

The Wizard Evaporator Control System is designed to control the room or zone temperatures and the evaporator operations for large ammonia and halocarbon refrigeration systems. The Wizard performs the functions of the following independent control systems:

- Evaporator Valve Group Status Monitor
- Multi-Function Defrost Clock
- Temperature Control
- Temperature Monitoring and Alarming
- Refrigerant Gas Leak Monitor
- Load Shedding Control
- System Shutdown
- Humidity Monitor
- De-Humidification
- Temperature Recorder
- Alarm System

Evaporator Valve Group Status Monitor

The Wizard has a series of status LEDs on the front panel that provide an easy method to determine the status of the Evaporator Valves and contactors.

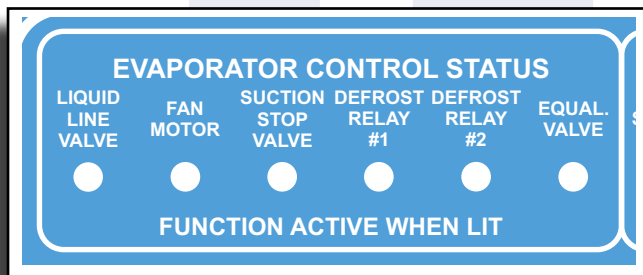

Defrost Control

The Wizard is an electronic control and time clock. The time clock can operate up to 12 defrost cycles per day with three separate defrost schedules as well as manual defrost. The defrost can be either gas, electric, water or off-time defrost. The Wizard will cycle all valves necessary to perform a defrost of some of the more complex refrigeration systems.

Defrost Features

Daily Schedules. The control has three unique defrost schedules: Weekday (Monday - Friday), Saturday and Sunday.

Automatically adjusts time for daylight savings.

Can schedule up to 12 defrost cycles per day.

Gas, Electric, Water, or Air defrosts.

Demand Defrost - Liquid Line Solenoid Feed Time. The Wizard can initiate its defrost cycles base upon the total liquid feed time. This option can be used to activate the system only when the "Number of Cycles per Day" set to zero. The liquid demand delay can range from 0 to 24 hours, in fifteen minute increments.



Demand Defrost - Remote Activation The Wizard has a digital input that forces the control into the defrost cycle. This input can be used to activate the system for an additional defrost cycle, or with the "Number of Cycles per Day" set to zero, the input can be wired to a gang defrost clock and a number of Wizards can be staged evenly or to a frost sensor and the Wizard will defrost only when necessary.

Defrost Termination. Any one of the following functions will terminate the Main Defrost Cycle:

Clicks-On Thermodisk (Dry Contact).

Suction Pressure Switch (Dry Contact).

Time. A user setable time in the control software will initiate and stop defrost.

Termination Temperature Sensor. A temperature sensor mounted in the coil will terminate the Defrost Cycle when the temperature exceeds a selectable Termination Setpoint.

Defrost Termination Log. The Wizard has a "Defrost Log" that records the duration of the previous 10 defrost cycle Defrost stages. This log can be used to determine whether the current defrost setup is operating efficiently or whether adjustments need to be made

Temperature Control

Each Wizard comes with a temperature sensor for monitoring or controlling the temperature in the refrigerated room. The Wizard will maintain the space temperature by cycling the LLS based upon a Temperature Setpoint and a plus/minus differential.

TEMPERATURE CONTROL & ALARMING

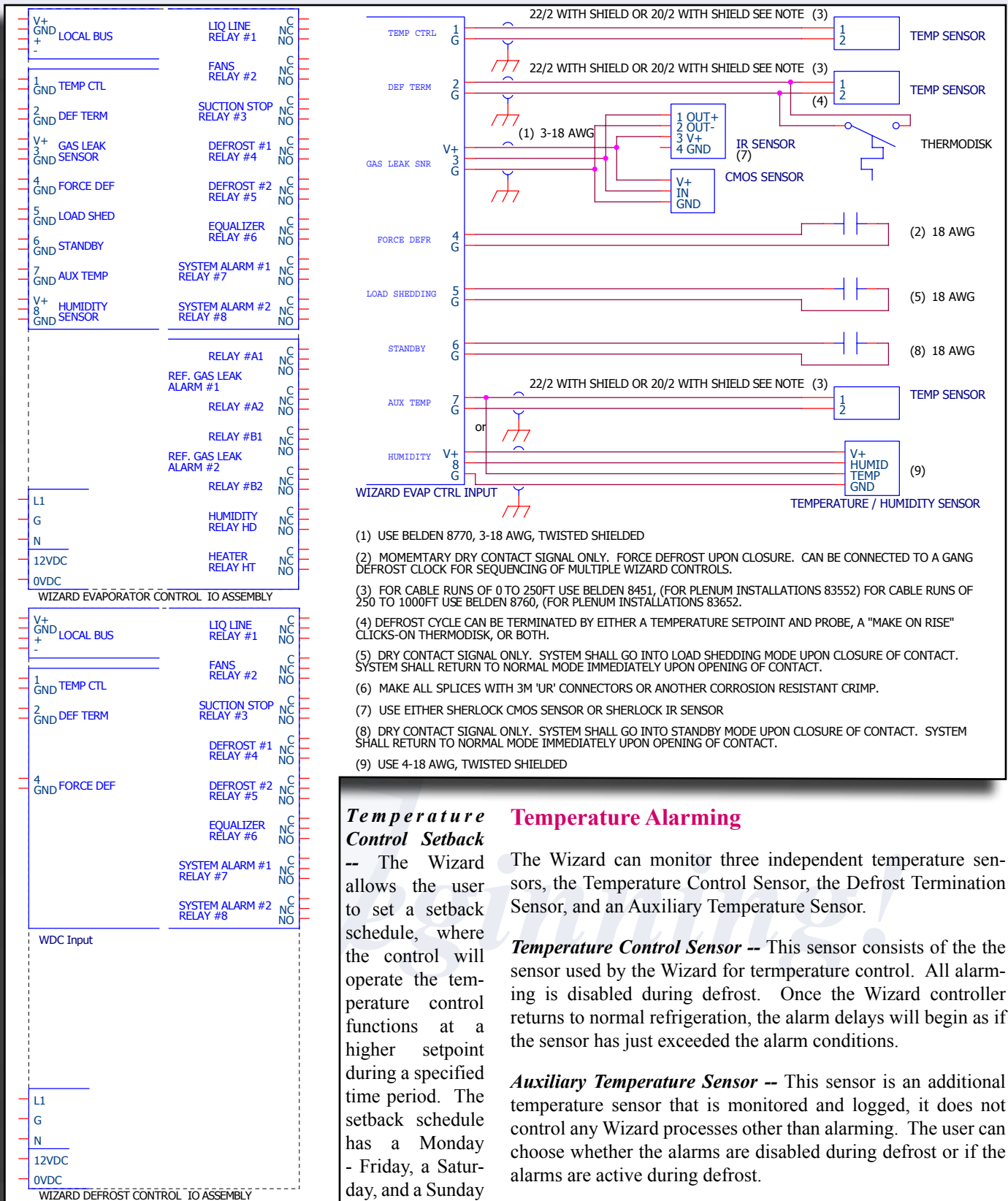

Temperature Control Setback

-- The Wizard allows the user to set a setback schedule, where the control will operate the temperature control functions at a higher setpoint during a specified time period. The setback schedule has a Monday - Friday, a Saturday, and a Sunday schedule.

Fan Cycling -- The Wizard can cycle the evaporator fans once the temperature within the space is met. The Wizard will also restart the fans after a settable delay to prevent stratification of the air.

Temperature Alarming

The Wizard can monitor three independent temperature sensors, the Temperature Control Sensor, the Defrost Termination Sensor, and an Auxiliary Temperature Sensor.

Temperature Control Sensor -- This sensor consists of the sensor used by the Wizard for temperature control. All alarming is disabled during defrost. Once the Wizard controller returns to normal refrigeration, the alarm delays will begin as if the sensor has just exceeded the alarm conditions.

Auxiliary Temperature Sensor -- This sensor is an additional temperature sensor that is monitored and logged, it does not control any Wizard processes other than alarming. The user can choose whether the alarms are disabled during defrost or if the alarms are active during defrost.

Defrost Termination Sensor -- This sensor consists of the sensor used by the Wizard to terminate the defrost cycle based upon the coil temperature. Should this temperature read above

HOT GAS DEFROST

the setpoint level of the termination setpoint for over 30 minutes, the Wizard will activate its systems alarms.

The Wizard will activate its "System Alarm" relays when the space temperature exceeds the Hi Temp Alarm Limit for a duration longer than the Hi Alarm Delay or when the space temperature goes below the Lo Temp Alarm Limit for a duration longer than the Lo Alarm Delay. The Wizard will activate the System Alarm Relay based upon the following alarm conditions:

High Alarm . The space temperature must exceed the High Alarm Limit for a time period longer than the Hi Alarm delay. This function shall activate the control's "System Alarm Relay 2".

Low Alarm . The space temperature must be below the Low Alarm Limit for a time period longer than the Low Alarm delay. This function shall activate the control's "System Alarm Relay 1".

Termination Temperature High Alarm. The Wizard will activate alarms if the termination Click-On or the Termination Temperature does not recover within 30 minutes. This function shall activate the control's "System Alarm Relay 2".

Hot Gas Defrost								
Defrost Step	Step Name	Range	Relay / Valve / Circuit					
			Liquid Line Solenoid	Evaporator Fan	Suction Stop	Soft Gas Valve (Defrost #1)	Hot Gas Valve (Defrost #2)	Equalizer Valve
1	Normal Refrigeration		Cycling	On	Open	Closed	Closed	Closed
2	Pump Down	0-250 min	Closed	On	Open	Closed	Closed	Closed
3	Soft Gas	0-250 min	Closed	Off	Closed	Open	Closed	Closed
4	Defrost Cycle	0-250 min	Closed	Off	Closed	Open	Open	Closed
5	Drip Cycle	0-250 min	Closed	Off	Closed	Closed	Closed	Closed
6	Equalizing	0-250 min	Closed	Off	Closed	Closed	Closed	Open
7	Fan Start Delay	0-250 min	Open / Cycling	Off	Open	Closed	Closed	Closed
8	Normal Refrigeration		Cycling	On	Open	Closed	Closed	Closed

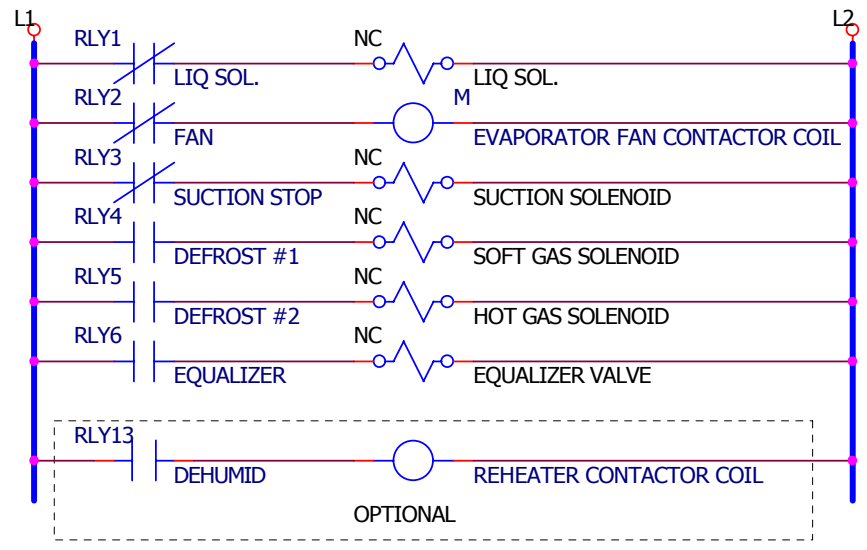

Refrigeration Leak Monitoring.

Most mechanical codes as well as ASHRAE 15-2004 and IAR 2-1999 require refrigerant leak detection within all occupied refrigerated spaces. The Wizard Evaporator Control System can make any refrigerated room Mechanical Code Compliant with the addition of a Sherlock Refrigerant Sensor.

The Wizard will activate alarms based upon two alarm levels. At the first alarm level, the Wizard will activate the Gas Leak Level One Alarm Relay, activating any alarm notification system connected to the Wizard. At the second alarm level, the Wizard will activate the Gas Leak Level Two Alarm relay, activating additional alarm indication equipment and any additional safety procedures as required by local codes. The Wizard gives the user an option to pump down, then isolate the evaporator coil should the leak concentration exceed level two.

Gas Leak Sensors

The Sherlock Refrigerant Gas Sensors are available in two varieties:

Ceramic Metal Oxide Semiconductor (CMOS) or Solid State Sensor

Non-Dispersive, Pyro-Electric Infrared Sensor.

The Wizard can monitor most third party Electro-Chemical sensors. (Check with a Genesis Factory Rep for more information.)

Alarm Level Settings

The Wizard allows you to set two unique Alarm Setpoints for the refrigerant gas sensor throughout its operating range. When an Alarm Setpoint is exceeded, a corresponding alarm relay is activated. The Wizard has a programmable option that will pump down and isolate the coil when the Sherlock sensor reading exceeds the Alarm Level 2 Alarm Setpoint.

Load Shedding

With the high costs of electricity and the requirements for reducing energy usage during periods of high demand, many companies are looking for assistance with their load curtailment programs.

ELECTRIC DEFROST & HUMIDITY

Some utilities are setting up Demand Response and Load Curtailment programs to compensate energy consumers for temporarily reducing their demand for power. Consumers reduce loads by shutting off equipment or adjusting their operations to reduce energy usage.

The Wizard Evaporator Control System can allow the user to change the Temperature Control Setpoint to a higher value in order to reduce energy demand.

During setup, the operator programs the following values:

Load Shedding Activation Method - Load Shedding can be activated by any one of the following four methods:

Dry Contact Closure - This input can be connected to a Load Monitor, a Current Switch to activate the Load Shedding routine when the facility approaches a high demand levels, or a manual switch.

Manually Forced - Front Panel Activation

Daily Schedule - The Wizard will go into Load Shedding at the same time daily.

Gencom Communications Interface - The Wizard Control Panels within a facility can be placed into Load Shedding via Gencom Communications System. From a computer panel, the operator can force all or some of the Wizard Panels into Load Shedding.

Shutdown (Standby)

Some refrigerated facilities need to be placed into Shutdown

or Standby at certain times, whether they are a seasonal facility (i.e. only stores produce during the harvest season), require maintenance or cleaning, or a production room where the room is not used during the overnight hours.

Another use of the Shutdown procedures is when a refrigerant leak is detected within the refrigerated space. By connecting the Dry Contact Input #6 on the Wizard IO Board to a refrigerant gas monitoring system (by others) or another Wizard configured to monitor for refrigerant leaks, the Wizard can properly isolate an evaporator coil during an alarm condition

Standby Activations Method - Standby can be controlled by any one of the following four methods:

Dry Contact Closure - Should a contact close across Input # 6 on the Wizard Input Board, the Wizard will go into Standby/Shutdown. The control will remain in Standby/Shutdown until the contact opens.

Manually Forced - Front Panel Activation

Daily Schedule - The Wizard will go into Standby/Shutdown at the same time daily.

Gencom Communications Interface - The Wizard Control Panels within a facility can be placed into Standby/Shutdown via Gencom Communications System. From a computer panel, the operator can force all or some of the Wizard Panels into Standby/Shutdown.

Standby Options

Fans Run During Standby - The option of whether to shut off the fans when the evaporator is shutdown.

Refrigerant Leak Monitoring during Standby - During cleaning of a process room, the temperature and humidity of the room can increase dramatically. These increases may cause false alarms with the leak alarms.

Humidity Monitoring

With an optional Remote Temperature and Humidity Sensor, the Wizard can Monitor, alarm, and log the humidity of the room.

De-Humidification

The Wizard will cycle a control relay based upon the humidity of the space. The Wizard will utilize available refrigeration to remove moisture from the air and will cycle a re-heat circuit to maintain the room temperature. This feature is not available on all models.

Misc. Features & Benefits

All Electronic Circuit Control -- Excellent performance in temperature range and areas where vibration and moisture causes mechanical systems to experience accelerated failure.

Electric Defrost								
Defrost Step	Step Name	Range	Relay / Valve / Circuit					
			Liquid Line Solenoid	Evaporator Fan	Suction Stop	Electric Defrost Pre-Heat Stage (Defrost #1)	Electric Defrost (Defrost #2)	Equalizer Valve
1	Normal Refrigeration		Cycling	On	Open	Closed	Closed	Closed
2	Pump Down	0-250 min	Closed	On	Open	Closed	Closed	Closed
3	Pre-Heat Cycle	0-250 min	Closed	Off	Closed	Open	Closed	Closed
4	Defrost Cycle	0-250 min	Closed	Off	Closed	Closed	Open	Closed
5	Drip Cycle	0-250 min	Closed	Off	Closed	Closed	Closed	Closed
6	Equalizing Cycle	0-250 min	Closed	Off	Closed	Closed	Closed	Open
7	Fan Start Delay	0-250 min	Open / Cycling	Off	Open	Closed	Closed	Closed
8	Normal Refrigeration		Cycling	On	Open	Closed	Closed	Closed

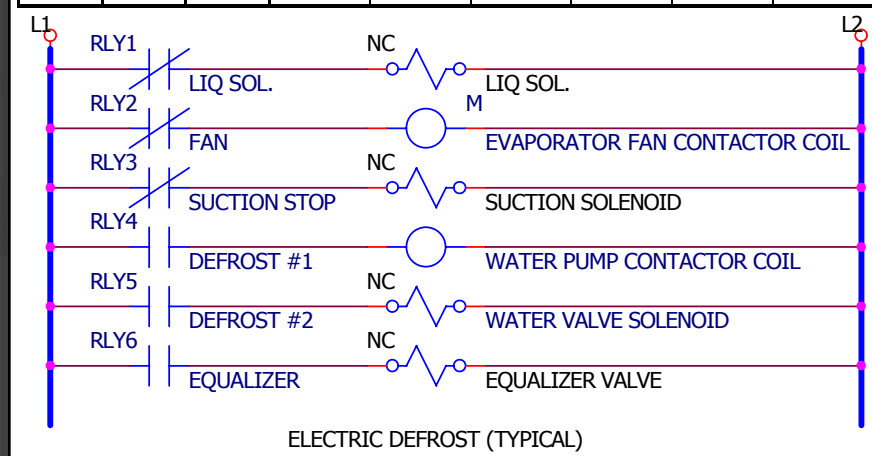

ELECTRIC DEFROST (TYPICAL)

WATER DEFROST / OFF-TIME DEFROST

Water Defrost								
Defrost Step	Step Name	Range	Relay / Valve / Circuit					
			Liquid Line Solenoid	Evaporator Fan	Suction Stop	Water Defrost Stage #1 (Defrost #1)	Water Defrost Stage #2 (Defrost #2)	Equalizer Valve
1	Normal Refrigeration		Cycling	On	Open	Closed	Closed	Closed
2	Pump Down	0-250 min	Closed	On	Open	Closed	Closed	Closed
3	Water Stage Cycle	0-250 min	Closed	Off	Closed	Open	Closed	Closed
4	Defrost Cycle	0-250 min	Closed	Off	Closed	Open	Open	Closed
5	Drip Cycle	0-250 min	Closed	Off	Closed	Closed	Closed	Closed
6	Equalizing Cycle	0-250 min	Closed	Off	Closed	Closed	Closed	Open
7	Fan Start Delay	0-250 min	Open / Cycling	Off	Open	Closed	Closed	Closed
8	Normal Refrigeration		Cycling	On	Open	Closed	Closed	Closed

WATER DEFROST (TYPICAL)

Multiple Power Supply Capability -- The control power supply is a "universal" switching, dual voltage power supply. The input range for the control module is 100-240 VAC - 50 / 60 cycle - single phase power.

Data Log Graphing And Printing

The Wizard will record 1500 temperature log entries into its internal memory. The Logging Interval can be set from 1 minute to 120 minutes. This information is retrievable via the front display or with the GenCom for Windows software package. With the optional GenCom Communication Kit the Wizard can be operated remotely. The GenCom Kit allows the user to view and change the settings, view and respond to alarm conditions, check and report the status of all of the Wizard at the site and place any of the controls into manual defrost. One kit can operate up to 250 Genesis controls in one location. If the user has the Premium Model, GenCom can be used to graph the data log.

To read this stored data, the facility must have a GenCom Communications Network installed and connected to either a modem or directly to a computer. The computer operator can then download the data log, print the graphs of the logged data, and store this data either on the computer hard/floppy disk or print the data in a table format.

Software Access "Keylock" -- The Wizard is keylock protected with two levels of access. No action can be taken without properly unlocking the control.

Menu Structure -- The Wizard has a menu that permits the end user to develop a defrost system for their application while eliminating a defrost operation that can cause damage to the evaporator.

Manual Single Step Defrost Cycling -- Maintenance personnel can cycle through each step of a defrost cycle in a brief period of time in order to check each valve operation during the defrost cycle.

Enclosure -- The standard unit comes in a metallic, NEMA 1 enclosure. Optional NEMA 4X or Panel Mount configurations are available. The watertight enclosure permits the installation of the Wizard in areas where it is necessary to wash down the room. The Wizard could be mounted on the exterior of the building.

Remote Communications

GenCom Communications allows the computer operator to access the controllers within a facility via a PC. All control programming and logging functions are accessible and can be set or changed from the computer. The user can view all text and data logs, make programming changes to the controller, initiate defrost cycles, and investigate alarm conditions.

Off-Time Defrost								
Defrost Step	Step Name	Range	Relay / Valve / Circuit					
			Liquid Line Solenoid	Evaporator Fan	Suction Stop	Water Defrost Stage #1 (Defrost #1)	Water Defrost Stage #2 (Defrost #2)	Equalizer Valve
1	Normal Refrigeration		Cycling	On	Open	Closed	Closed	Closed
2	Defrost Cycle	0-250 min	Closed	On	Open	Closed	Closed	Closed
3	Normal Refrigeration		Cycling	On	Open	Closed	Closed	Closed

OFF-TIME DEFROST (TYPICAL)

SPECIFICATIONS & HOUSING OPTIONS

Specifications

The Wizard Evaporator Control System (WEC) and Wizard Evaporator with Humidity Control (WEC-H) is compliant with ASHRAE 15-2007 and the MECHANICAL CODE requirements for refrigerant gas monitoring. The Wizard Defrost Control WDC does not have all of the features listed below. Please see input /output mapping on page 3.

Power	100 to 240vac, 50/60 hz, 2.5 Amps
Inputs	Up to Three (3) NTC Thermistor Sensors One (1) SHERLOCK sensor <i>Cmos or IR</i> One (1) Humidity Sensor, 10-90% RH (-H Only) Three dry contacts -- <i>Force Defrost, Shutdown, Load Shedding.</i>
Outputs	Up to Fourteen (14) SPDT, 1 Form C, 250Vac, 3.15Amp relays. (Eight (8) on WDC)
Alarms	System Alarms (2 relay) Low Temperature High Temperature Humidity Alarms (-H Only) Termination Failure / Coil Recovery Refrigerant Gas Leak Alarm Two alarm levels (2 SPDT Relays per level)

Display 2 lines by 20 characters
Alphanumeric LCD with back light
Evaporator Control Status LEDES -- indicates Control Operating Status of Evaporator Controls Circuits
Alarm Status LEDES -- indicates Alarm Status

Keypad 5 tactile pushbuttons
Scroll up Scroll down Select/Edit/Change Force Defrost Start/Advance

Alarm Indicators

LCD Name, description, and current reading of alarming sensor

Buzzer piezo-electric, 90db @10ft, silenceable

Status LED Two on front panel of control. Indicates alarm status of the System Alarm and the Refrigerant Leak Alarm

Strobe Light (*Optional*) Mounted on the enclosure, activates during any alarm condition.

Optional Dual Variable speed control relay (Fans, Compressors, Etc.)



NEMA 1 Compliant Enclosure - This enclosure is intended for indoor use only primarily to provide a degree of protection against contact with the enclosed equipment. The enclosure is not designed to provide protection from water or to be placed in a hazardous environment. Mount only in Pollution Level 2 environments, ie. environmentally controlled offices, control rooms, or environmentally controlled machine rooms.

Dimensions Inches (mm) 12.0 x 9.5 x 5.0
(305 x 241 x 127)



NEMA 4X Compliant Enclosure - This enclosure is intended for either indoor or outdoor use, 0 to 50 °C, to provide a degree of protection against corrosion, windblown dust and rain, splashing water, and hose directed water.

Dimensions Inches (mm) 12.13 x 14.88 x 6.88
(308 X 378 X 175)



NEMA 1 Panel Mount Option - The control and display assemblies must be suitably mounted in an enclosure. The Faceplate may be surface mounted onto a Nema 1 enclosure. The IO Board Assembly must be mounted within an enclosure providing at least Nema 1 protection.

Dimensions Inches (mm) 10.2 x 8.5 x 2.0 (259 x 216 x 51) PM Faceplate
10.6 x 8.5 x 3.0 (269 x 216 x 76) PM Backplate



ETL Listed
Conforms To UL Std. 3111-1
Certified To CAN/CSA
C22.2 Std. No. 1010.1

REMOTE COMMUNICATIONS



REMOTE COMMUNICATIONS

Remote communications to a facility utilizing the Wizard Evaporator Control System is accomplished by using the Gencom Remote Communications Software and Interface. Gencom is a Microsoft Windows based software system that displays the operating status of Genesis International, Inc. control system within a facility. Gencom allows the user to change all operation parameters on each control system, view their logged data, initiate all user driven operations (i.e. force a defrost cycle and test alarm circuitry) and observe all operational parameters on each control.

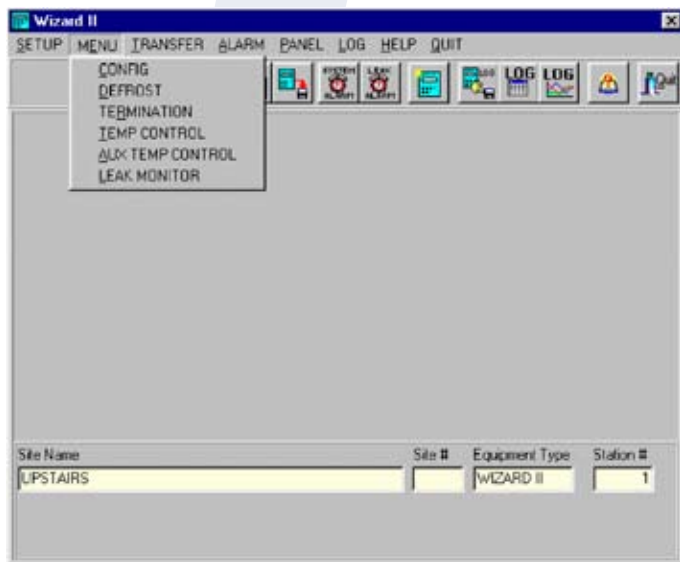

Gencom can be configured to operate in two distinct formats: Remote and Local.

Remote. A refrigerated warehouse has a network of Wizards interconnected to a Gencom Interface Box and a 33.3kbaud Modem. A computer operator utilizing Gencom can dial into the equipment modem and interrogate the Wizard control panels to identify sources of alarms or to change a operating parameter.

Local. A refrigerated warehouse plant manager's computer has the Gencom software installed in his computer and the network of Wizards interconnected to a Gencom Interface Box through his serial port. From his/her desk, the operator

can interrogate the Wizard control panels to identify sources of alarms or to change a operating parameter

Network Wiring

Gencom communicates with each controller via an RS-485 protocol, two wire link. Use a 2-22 AWG Shielded cable, Belden 8451.

A typical Gencom system consists of the following with these minimum ratings:

Computer

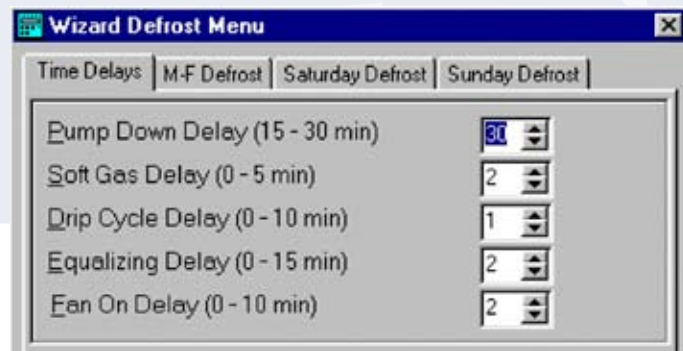

Hardware:

- Pentium 133 MHz class processor
- 3.5in floppy drive
- 32 MB Ram
- 16 MByte Hard Drive space available.
- 256 Color, 800x600 pixel VGA
- Mouse
- Serial Port, RS-232
- Parallel Port (for optional printer)

Software:

- Windows 98 or greater

Modem For Remote Installations Only

- 14.4 kbaud

Remote Control Access

An operator can access, modify and operate the Wizard Control System from a remote location. All changes can be made via the Front Panel (as if the operator was standing in front of the controller) or by using "worksheets" to make the changes, then uploading the new configuration

REMOTE COMMUNICATIONS

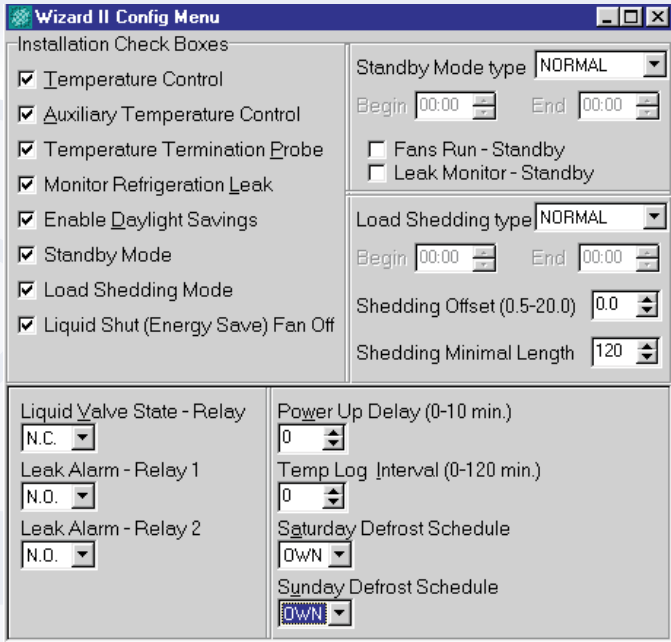

Temperature Data Logging

The Wizard will record 1500 temperature log entries into its internal memory. The Logging Interval can be set from 1 minute to 120 minutes. This information is retrievable via the front display or with the GenCom for Windows software package. With the optional GenCom Communication Kit the Wizard can be operated remotely. The GenCom Kit allows the user to view and change the settings, view and respond to alarm conditions, check and report the status of all of the Wizard at the site and place any of the controls into manual defrost. One kit can operate up to 250 Genesis controls in one location. If the user has the Premium Model, GenCom can be used to graph the data log.

To read this stored data, the facility must have a GenCom Communications Network installed and connected to either a modem or directly to a computer. The computer operator can then download the data log, print the graphs of the logged data, and store this data either on the computer hard/floppy disk or print the data in a table format.

Log Data Graph for WIZARD Control Site Name: UPSTAIRS Site # Station #6 Description:
High Value = 45.5 Low Value = 35 Average Value = 40.6
High Value = 0 Low Value = 0 Average Value = 0.0

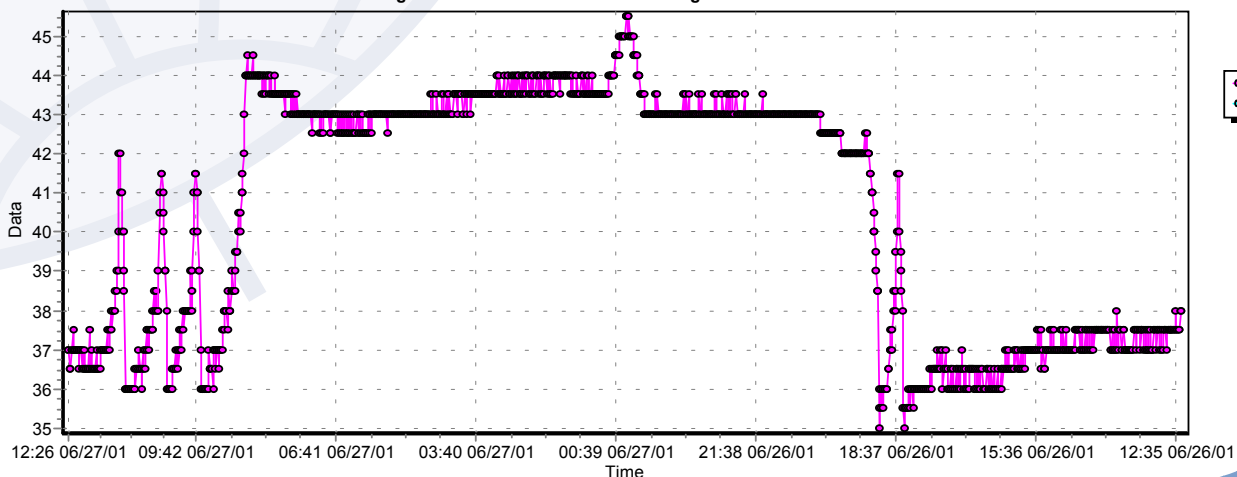

Remote Communications



GenCom Communications allows the computer operator to access the controllers within a facility via a PC. All control programming and logging functions are accessible and can be set or changed from the computer. The user can view all text and data logs, make programming changes to the controller, initiate defrost cycles, and investigate alarm conditions.



Wizard FOR SPECIAL APPLICATIONS

CRITICAL PRODUCTS CONTROL SYSTEM (WCPCS)



The **Wizard Critical Products Control System (WCPCS)** is specially designed Wizard manufactured specifically to control the room or zone temperatures and the evaporator operations for critical product refrigerated storage rooms.

The WCPCS performs the functions of the following independent control systems:

- Temperature Control**
- Defrost Clock**
- Temperature Monitoring and Alarming**
- Refrigerant Gas Leak Monitor**
- Door Alarm**
- System Shutdown**
- Temperature Recorder**
- Alarm System**

The WCPCS adds a door alarm input for open door warning and compressor proofing input to insure starting of the compressor in critical situations.



Wizard Critical Products Control System – Dual Unit (WCPCS-D): Two Wizard Critical Product Control Systems, mounted in a NEMA 1 steel enclosure, is a defrost clock, temperature control designed to operate evaporators in a refrigerated room. Using the “Control Status” input both Wizards work in tandem for complete control system redundancy in critical areas. Each control sends a signal to the status input to communicate when a control is in defrost or has a problem.



Dual-FailSafe Redundant Control Operation

Genesis International will factory mount both controls into a main NEMA 4 box and wire all inputs and outputs to a common Input / Output to make for easy field wiring. Genesis tests the dual redundant unit for a full day before shipping to ensure the

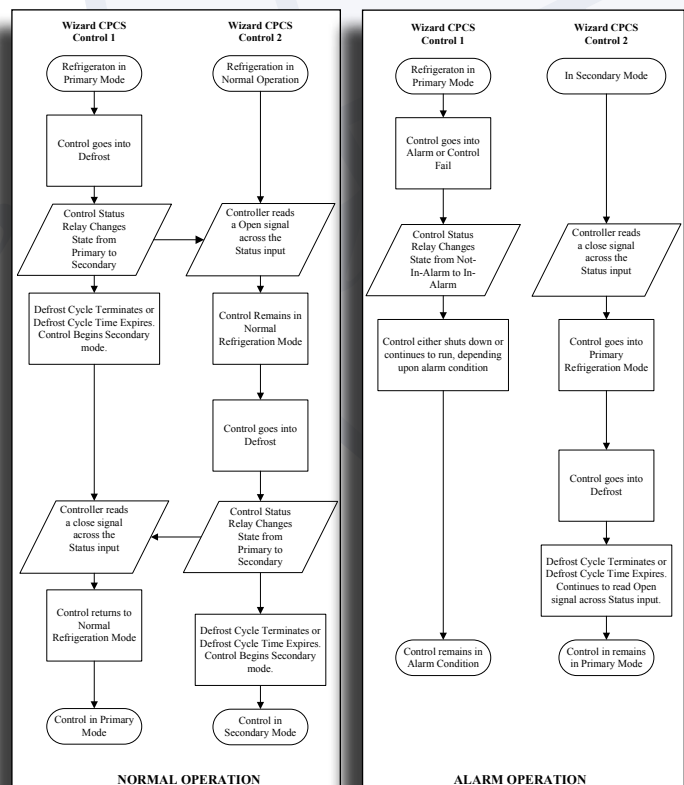

CRITICAL PRODUCTS CONTROL INPUT/OUTPUT AND WCPCS-D DUAL SYSTEM WIRING DIAGRAM

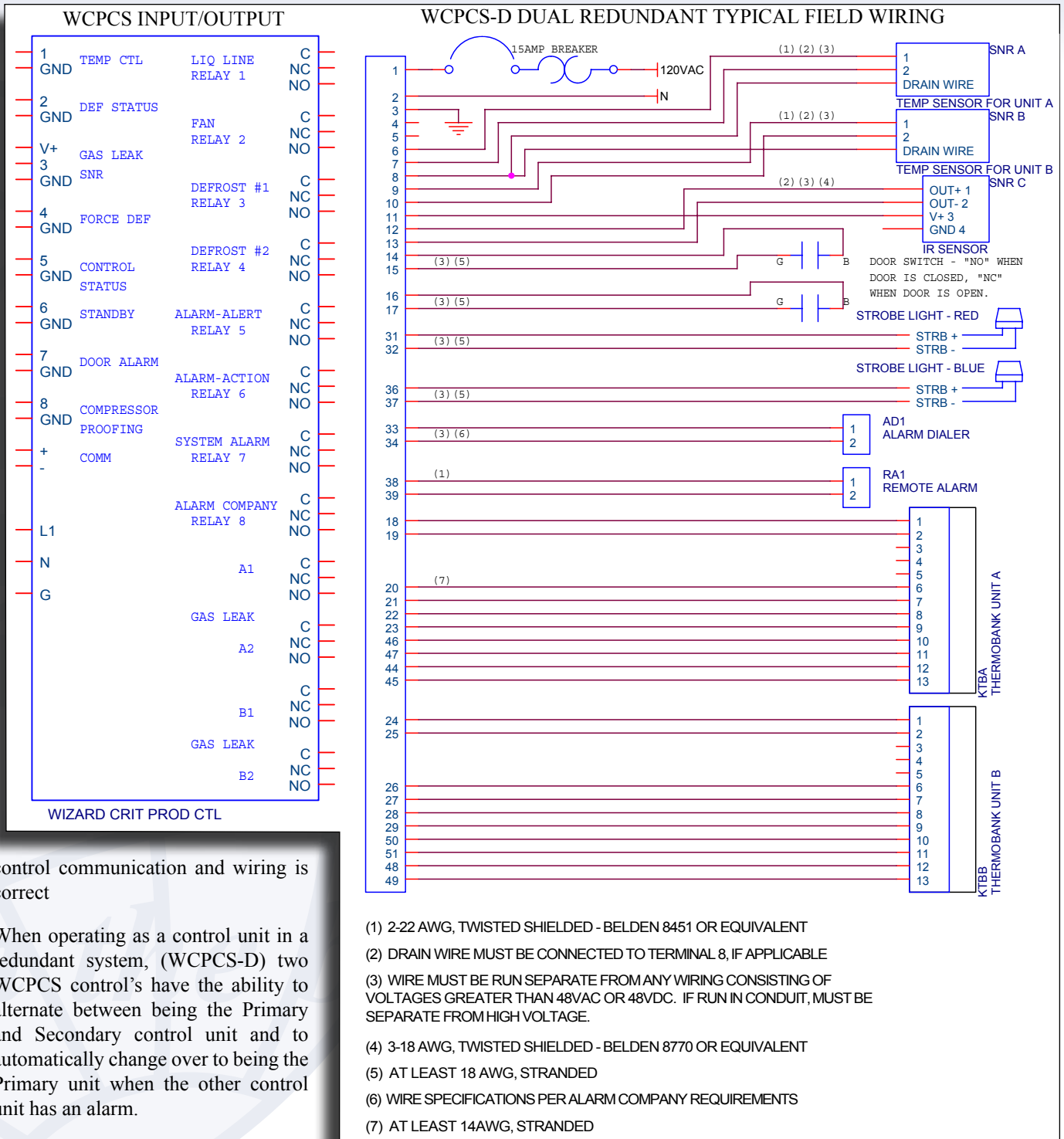

control communication and wiring is correct

When operating as a control unit in a redundant system, (WCPCS-D) two WCPCS control's have the ability to alternate between being the Primary and Secondary control unit and to automatically change over to being the Primary unit when the other control unit has an alarm.

By connecting the Control Status relay on Unit #1 to the Control Status Input on Unit #2, Unit #1 can "tell" Unit #2 its operating status and whether it is in alarm or defrost. In this way each control takes turns being the primary unit and then being the Secondary unit. Therefore one control can completely lose power or have a fault and the other control will take over the entire system.

The WCPCS control adds a compressor proofing input to acknowledge a compressor start. The WCPCS compressor proofing input will send out an alarm if the compressor fails to send

a signal to the control alerting factory personell of a potential problem with the compressor.

The WCPCS also has a door alarm switch input to monitor and alarm if a critical door is left open too long letting out cool air. The alarm time length of the open door switch is settable in the field and can be changed at any time. Genesis International's door alarm switch part number 28-0117 is available for this application.

Wizard FOR SPECIAL APPLICATIONS

2 & 4-ZONE EVAPORATOR CONTROL SYSTEM



The **Wizard 2-Zone (W2EC)** and **4-Zone (W4EC)** Evaporator Control Systems allow you to control and monitor the temperature and defrost of up to 4 valve groups in the same room from one main "Master" Wizard control using a single room temperature sensor. Each control can defrost together or separately depending upon time or using a separate temperature termination sensor input for each system.

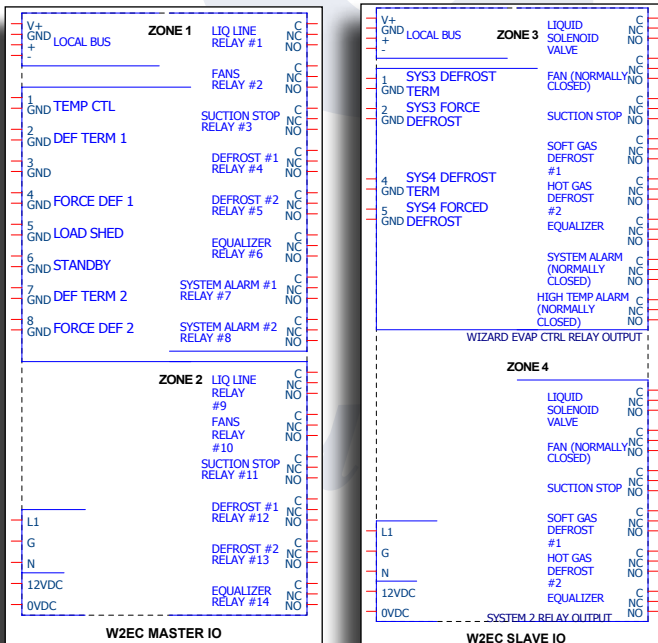

One Primary "Master" Controls zones one and two and a Secondary "Slave" controls zones three and four and is networked back to the "Master" control. The "Master" control communicates and controls the Auxilliary "Slave" control so the user can view and change settings from one main panel.

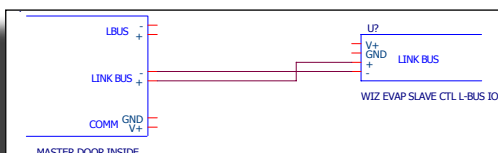

1 TO 3 ZONE EVAPORATOR CONTROL SYSTEM WITH LEAK DETECTION

The Wizard Single Zone Main "Master" (WECM-L) and single Slave (W2EC-L) and 3-Zone (W3EC-L) Main - 2 Secondary "Master - Slave", Evaporator Control Systems with Refrigerant Leak Detection allow you to control and monitor the temperature and defrost of up to 3 valve groups in the same room from one main "Master" Wizard control using a single room temperature sensor and have Refrigerant Leak Detection adding one Sherlock Leak Sensor. Each control can defrost together or separately depending upon time or using a separate temperature termination sensor input for each system.

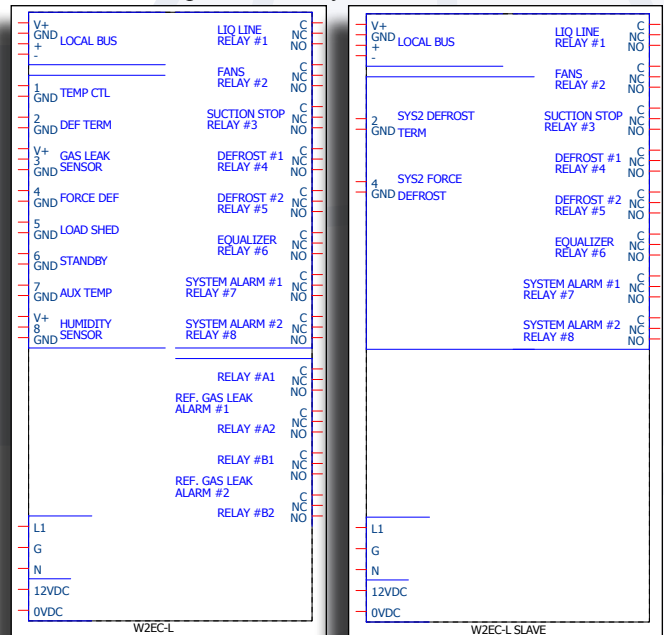

DUAL LIQUID LINE EVAPORATOR CONTROL

The **Wizard Evaporator 2 Liquid Line Control Kit (WEC-2L)** will control two (2) separate liquid line temperatures in one unit. This system also includes the Sherlock refrigerant leak monitoring option.

This control has all of the standard features of the WEC, but adds a second Liquid Solenoid Valve relay.

Please contact Genesis International, Inc. for additional **Wizard's** with different features.

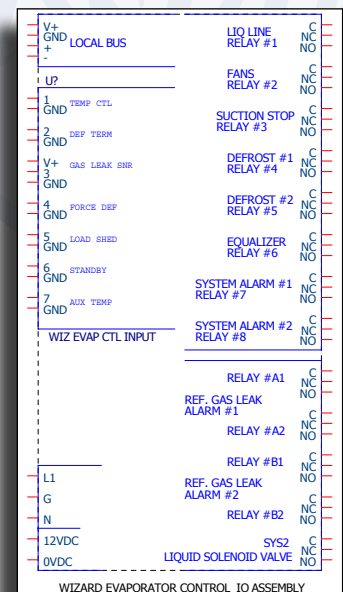

TEMPERATURE SENSOR & HUMIDITY SENSOR

Temperature Sensor (Part number 80-0240. Comes standard with all *Wizard* Evaporator Controls.)

The Temperature Sensor is a high-precision NTC thermister. The sensor is a rubber coated thermistor with a 5 second reaction time rating. The coating is highly resistant to most solvents and chemicals. The sensor range is from -50°F to 145°F and is accurate to 1.0°F. Standard sensor cable is 20 feet long. Can also be used for temperature termination.

When used as a temperature gauge, this thermistor requires no adjustment between the control circuit and the sensor. This insures a temperature precision of ± 0.3 °C.



SPECIFICATIONS

- ENCLOSURE** Molded Nylon
- LEAD LENGTH** 20 feet (6.1 Meters)
- NOMINAL ZERO POWER RESISTANCE** 10.0 K Ohm $\pm 1\%$ at 25°C
- OPERATION TEMPERATURE RANGE** -58 to 230°F (-50 to 110°C)
- DISSIPATION CONSTANT** 3mW $\pm 1\%$
- THERMAL TIME CONSTANT** 75 Seconds
- DIELECTRIC WITHSTAND VOLTAGE TEST**
After 1000 VAC is applied across leads, no change in characteristic of the thermistor were detected.

CABLE REQUIREMENTS

Stranded Wire, Twisted Pair, Shielded
 For cable runs of 0 to 250 ft
 Use 2-22 AWG, Belden 8451 or equivalent
 For cable runs over 250 ft - Use 2-18 AWG, Belden 8760 or equivalent.
 (Up to 1,000 Feet approx.)

Remote Indoor & Outdoor Temperature and Humidity Sensor

(ONLY USED WITH THE WEC-H OPTION)

INDOOR HUMIDITY SENSOR These sensors consist of a microprocessor based control module that reads the temperature and humidity with internal sensors processes the raw data, and transmits the information to the HVAC control via a 4 wire communications link. The sensor is powered by 8 to 12VDC supplied by the control, and is wall mountable up to 250 feet from the controller.



CALIBRATION The temperature sensor is accurate to ± 0.5 °F. The sensor is calibrated at the controller.

OPERATING RANGE

Temperature Sensor -40°F to 150°F
 Humidity Sensor -40°F to 150°F, 10 to 90% RH (non-condensing)

HOUSING

- Indoor Sensor* NEMA 1 Housing.
- Outdoor Sensor* NEMA 3R Semi-Rigid Polypropylene 4X4 box with a filtered inlet.

POWER INPUT

12VDC, 400 mAmps

OUTDOOR HUMIDITY SENSOR



REFRIGERANT SENSOR OPTIONS

Solid State CMOS Sensor

(Only available on control's with the Sherlock Leak Detection (-L) option.)



The CMOS Refrigerant gas sensor was designed to detect for the presence of a refrigerant gas within an enclosed space. The sensor is mounted within the space to be monitored and connected by cable to the monitoring device. Each sensor is calibrated to a clean air base zero level at the factory prior to shipment. There are three models of the CMOS sensor, one for CFC/HCFC gases, one for HFC gases and one for Ammonia.

NOTE: These sensors, due to their nature, are susceptible to detection of non-refrigerant gases and cannot distinguish the presence of different refrigerant gases, only that there is a gas present. The CMOS sensor will detect concentrations of gasoline, diesel, and propane exhaust and fumes from solvents, paints, cleansers, and others (Please call Genesis Customer Support for more information.) The stated accuracy is a best case and some refrigerant blends can be off as much as 100% of the Sherlock Control ppm reading.

NOTE: Continued exposure to refrigerants and other gases and humidity and other adverse conditions can severely decrease sensor life.

CMOS SENSOR SELECTION CHART

Model 82-0100 -- CFC/HCFC gases

R-11	R-400(Lintern)	R-412A(TP5R)
R-12	R-402B(Hp81)	R-411B(G2108B)
R-13	R-403A(R-69S)	R-500(AZ50)
R-22	R-403B(R-69L)	R-502
R-32	R-405A(G2015)	R-508A(Klea5R3)
R-113	R-406A(CHG)	R-509A(TP5R2)
R-124	R-409A(FX56)	R-411A(G2108A)
R-142B		

Model 82-0101 -- HFC gases

R-23	R-401C(MP62)	R-410B(9100)
R-123*	R-404A(HP62)	R-413A
R-125	R-407A(Klea60)	R-503
R-134A	R-407B(Klea61)	R-507A(AZ50)
R-143A	R-407C(9000)	R-508B(SUVA95)
R-152A	R-407D(Klea)	R-401A(Mp89)
R-408A(FX10)	R-401B(Mp66)	R-410A(AZ20)

Model 82-0102 -- Ammonia

R-717

* Although R-123 is an HCFC type refrigerant, testing has shown the HFC sensor is better for detecting this gas

Ammonia Electro-Chemical Refrigerant Gas Sensor

(Only available on control's with the Sherlock Leak Detection (-L) option.)

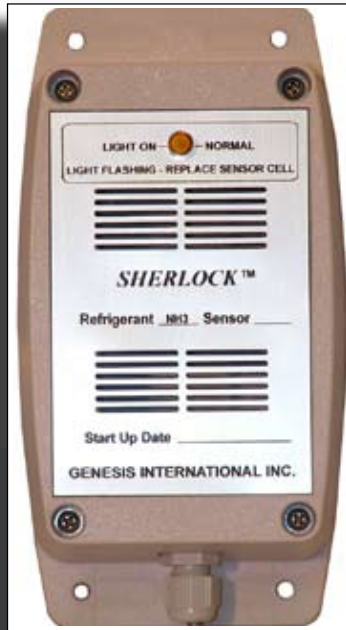

The **SHERLOCK** Ammonia (NH₃) "Electro-Chem" was designed to monitor for the presence of Ammonia within an enclosed space. The sensor is mounted within the space to be monitored and connected by cable to a **SHERLOCK** or **Wizard** Control. The Electro-Chem comes in a NEMA 3R Grey plastic box (pictured) or a NEMA 3R Washdown Housing. The Electro-Chem is a reliable method of monitoring for Ammonia leaks in environments that have high humidity.

The LED on the front of the sensor remains lit when the sensor is operating within parameters. The LED will flash when the sensor element needs to be changed. After changing the sensor element, a push button on the sensor will reset the timer for when the next time the element needs to be changed out.

Typical applications include:

- Refrigeration Mechanical Rooms
- Refrigerated Rooms
- Food Processing Plants

SPECIFICATIONS

DIMENSIONS 6.88 x 3.58 x 2.13
Inches (mm) (175 x 91 x 54)

OPERATING ENVIRONMENT

TEMPERATURE

Machine Room Model Part Number 82-0460
32°-110°F (0°-43.3°C)

Freezer Room Model Part Number 82-0461
-40°-110°F (-40°-43.3°C)

HUMIDITY 0 - 90% RH Non-Condensing

LIFE EXPECTANCY Average of 24 Months, Sensor Cell can be Field Replaced



WARNING!!! The Electro-Chemical sensor will pick up all types of ammonia gas including fumes from household cleaners containing ammonia and is not to be applied into all refrigerated storage applications where other toxic gases are used in the same room. Some installations are not suitable for Electro-Chemical technology. Misapplication may result in damage to sensor. Contact the factory for a specific list of approved applications.

REFRIGERANT SENSOR OPTIONS

Infrared Gas Specific Sensor

(Only available on control's with the Sherlock Leak Detection (-L) option.)

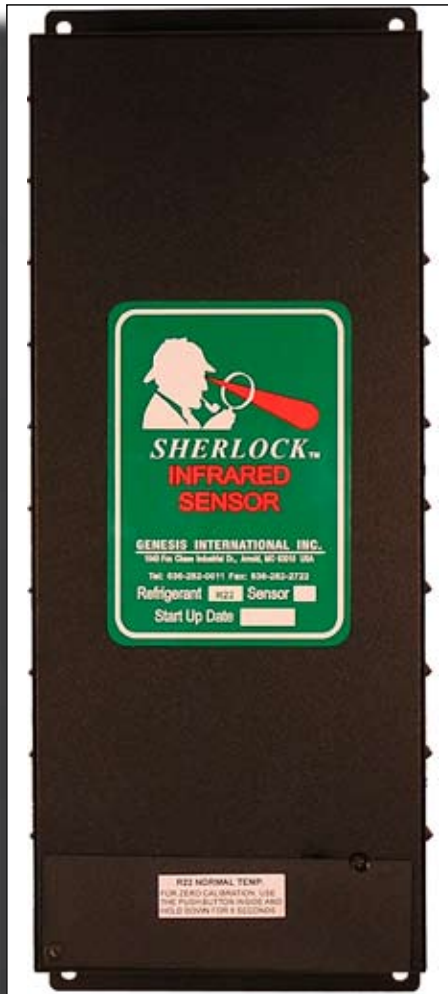

SHERLOCK NON-DISPERSIVE IR REFRIGERANT GAS SENSOR was designed to monitor for the presence of refrigerant gases within an enclosed space. The sensor is mounted within the space to be monitored and connected by cable to a **SHERLOCK, Wizard** or EMS System. Each sensor is calibrated to a specific refrigerant gas. The IR comes in two different styles depending upon the monitoring environments: machine room and cold room for refrigerated applications in NEMA 3R Aluminum (Pictured). Water-tight ABS fiberglass housing for Wash down protection (NEMA 3R) and Stainless Steel enclosure also available for special applications.

The IR Sensor is a reliable method of monitoring for refrigerant gas leaks in environments that have air quality problems. The IR sensor will eliminate many false alarms in environments that contain gasoline, diesel, and propane exhaust and fumes from solvents, paints, cleansers, and others (Please call Genesis Customer Support for more information).

SPECIFICATIONS

ENCLOSURE RATING	NEMA 3R, Aluminum, Black Powder Coat
DIMENSIONS	12.86 x 4.8 x 2.44
Inches (mm)	(326.5 x 122 x 62)
OPERATING ENVIRONMENT	
TEMPERATURE	
Machine Room Model	32°-110°F (0°-43.3°C)
Freezer Room Model	-40°-110°F (-40°-43.3°C)
HUMIDITY	0 TO 90% RH Non-Condensing
POWER INPUT	12VDC, 0.4 A
OUTPUTS	0 to 20 mA
EFFECTIVE RANGE	15 to 1500ppm (Control Dependent)
SENSITIVITY	±1 ppm at 25 ° C, 45% RH
RESOLUTION	1 ppm
RESPONSE TIME	Less Than 60 Seconds
CALIBRATION	Every 6 Months
WARM-UP TIME	Readings will stabilize after 3 hrs

AVAILABLE GAS SENSORS (Part Numbers)

Machinery Room/Walk-In Cooler Application

R11 - 60-0057	R12 - 60-0104	R22 - 60-0053
R23 - 60-0232	R114 - 82-0260	R123 - 60-0137
R134A - 60-0054	R401A - 60-0465	R402A - 82-0249
R404A - 60-0052	R407A - 60-0223	R407C - 60-0214
R408A - 60-0184	R409A - 60-0066	R410A - 60-0165
R500 - 60-0067	R502 - 60-0059	R507 - 60-0061
R438A - 60-0246	Ammonia/NH ₃ - 60-0095	

Extended Temperature/Freezer Application

R11 - 60-0058	R22 - 60-0047	R402A - 60-0142
R404A - 60-0051	R408A - 60-0065	R502 - 60-0060
R507 - 60-0062	R438a - 60-0464	
Ammonia/NH ₃ - 60-0096		

Call factory for list of additional refrigerants



WARNING!!! The infrared sensor is not to be applied into all refrigerated storage applications where other toxic gases are used in the same room. Some installations are not suitable for Infrared technology. Misapplication may result in damage to sensor. Contact the factory for a specific list of approved applications.

APPLICATIONS

Typical applications include:

Wineries	HVAC Chiller Equipment Rooms
Bakeries	Refrigeration Mechanical Rooms
Refrigerated Rooms	Food Processing Plants

Wizard OPTIONS

STANDARD KITS INCLUDE:

CONTROL COMPLETE WITH NEMA 1 STANDARD HOUSING & INTERNAL POWER SUPPLY, TEMPERATURE SENSOR(S), O & M MANUALS

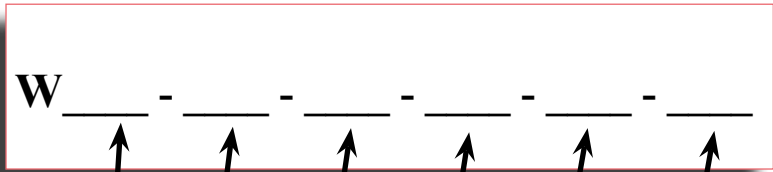

BASIC CONTROLS

DEFROST CONTROL SYSTEM	WDC
EVAPORATOR CONTROL SYSTEM	WEC*
2 STAGE EVAP CONTROL SYSTEM	W2EC
4 STAGE EVAP CONTROL SYSTEM	W4EC
1 STAGE EVAP W/LEAK DETECTION	WECM-L*
2 STAGE EVAP W/LEAK DETECTION	W2EC-L*
3 STAGE EVAP W/LEAK DETECTION	W3EC-L*
CRITICAL PRODUCTS CONTROL SYSTEM	WCPCS*
EVAP CNTRL W/ 2 LIQUID LINE RELAYS	WEC-2L*

VARIABLE SPEED EVAPORATOR FAN CONTROL

NONE	BLANK
VARIABLE SPEED - VFD	VFD

HUMIDITY SENSOR (OPTION FOR WEC ONLY)

NONE	BLANK
HUMIDIFICATION / DE-HUMIDIFICATION	H

DATA LOGGING

(STANDARD ON ALL CONTROLS EXCEPT WDC)
(REQUIRES GENCOM SOFTWARE)

NONE	BLANK
GENCOM INTERFACE CAPABLE	C

ENCLOSURE OPTION

NEMA 1 STANDARD	BLANK
PANEL MOUNT	PM
NEMA 4X	4
DUAL MOUNT NEMA 1	D

FACTORY MOUNTED STROBE LIGHT

NONE	BLANK
STROBE (RED, AMBER, BLUE)	S

*REFRIGERANT LEAK MONITORING

Only includes Input / Output for Option. Cost varies with sensor needed. See the Sherlock Refrigerant sensor section for more information.



GENESIS INTERNATIONAL, INC.

1040 FOX CHASE INDUSTRIAL DRIVE
ARNOLD, MISSOURI 63010

PHONE: (636) 282-0011
FAX: (636) 282-2722

WEBSITE:
WWW.GENESIS-INTERNATIONAL.COM

EMAIL:
MAIL@GENESIS-INTERNATIONAL.COM