



GENESIS INTERNATIONAL, INC.

SHERLOCK™ SOLID-STATE SENSOR NEMA 3R



SHERLOCK NEMA 3R CMOS SENSOR

GENERAL

SHERLOCK CERAMIC METAL OXIDE SEMICONDUCTOR (CMOS) REFRIGERANT GAS SENSOR was designed to detect for the presence of a refrigerant gas within an enclosed space. The sensor is mounted within the space to be monitored and connected by cable to the monitoring device. Each sensor is calibrated to a clean air base zero level at the factory prior to shipment. There are three models of the CMOS sensor, one for CFC/HCFC gases, one for HFC gases and one for Ammonia. The CMOS Sensor should be utilized as a signal source for a **SHERLOCK** Refrigerant Gas Monitoring System, *Wizard* Evaporator Control or **Walk-In** Monitor & Control.

APPLICATIONS

Typical applications include:

- | | |
|--------------------|--------------------------------|
| Refrigerated Rooms | HVAC Chiller Equipment Rooms |
| Wineries | Refrigeration Mechanical Rooms |
| Bakeries | Food Processing Plants |

SPECIFICATIONS

ENCLOSURE RATING	NEMA 3R
DIMENSIONS	7.32 x 5.94 x 6.54
Inches (mm)	(186 x 151 x 166)
POWER INPUT	12VDC, 250 mAMPs
OUTPUT	0.5 to 5 VDC
EFFECTIVE RANGE	20 to 1000 ppm Control and Refrigerant Gas Type Dependent
ACCURACY	+/- 10% to 50% of reading (Gas Dependent, Could be higher for some newer blends)
REPEATABILITY	±10% when proper calibration and Maintenance is followed.
AVAILABLE SENSORS	CFC / HCFC, HFC & Ammonia
OPERATING ENVIRONMENT	
TEMPERATURE	-25 to 120° F
HUMIDITY	0 TO 85% RH Non-Condensing
CALIBRATION	Every 6 Months
WARM-UP TIME	Reading will stabilize after 3 hours
LIFE EXPECTANCY	Average of 3 to 5 years in normal environments

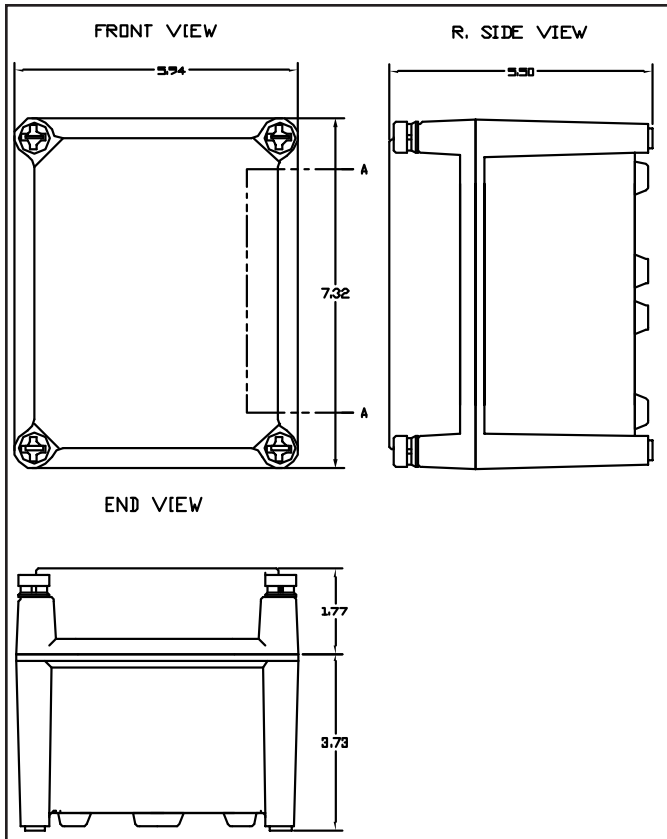

NEMA 3R DIMENSIONS



CMOS SENSOR MOUNTED IN HOUSING

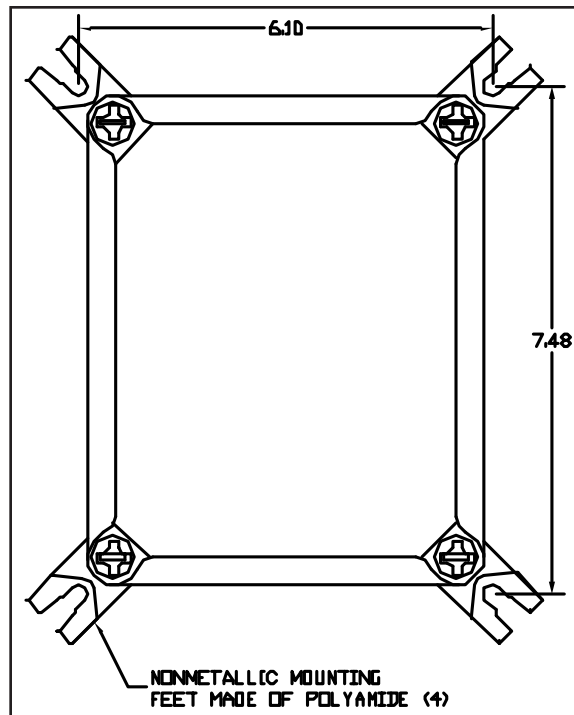

BACK OF HOUSING SHOWING MOUNTING FEET

CMOS SENSOR SELECTION CHART

Model 60-0113 NEMA 3R -- CFC/HCFC gases

R-11	R-400(Lintern)	R-412A(TP5R)
R-12	R-402B(Hp81)	R-411B(G2108B)
R-13	R-403A(R-69S)	R-500(AZ50)
R-22	R-403B(R-69L)	R-502
R-32	R-405A(G2015)	R-508A(Klea5R3)
R-113	R-406A(CHG)	R-509A(TP5R2)
R-124	R-409A(FX56)	
R-142B	R-411A(G2108A)	

Model 60-0128 NEMA 3R -- HFC gases

R-23	R-401C(MP62)	R-410B(9100)
R-123	R-404A(HP62)	R-413A
R-125	R-407A(Klea60)	R-503
R-134A	R-407B(Klea61)	R-507A(AZ50)
R-143A	R-407C(9000)	R-508B(SUVA95)
R-152A	R-407D(Klea)	R-401A(Mp89)
R-408A(FX10)	R-401B(Mp66)	R-410A(AZ20)

Model 60-0129 NEMA 3R -- Ammonia

R-717

NOTE: These sensors, due to their nature, are susceptible to detection of non-refrigerant gases and cannot distinguish the presence of different refrigerant gases, only that there is a gas present. The CMOS sensor will detect concentrations of gasoline, diesel, and propane exhaust and fumes from solvents, paints, cleansers, and others (Please call Genesis Customer Support for more information.) The stated accuracy is a best case and some refrigerant blends can be off as much as 50 to 100% of the Sherlock Control ppm reading.

NOTE: The stated average life expectancy for this sensor is 3 to 5 years, however, continued exposure to refrigerants and other gases and humidity and other adverse conditions can severely decrease sensor life.



GENESIS INTERNATIONAL, INC.

1040 FOX CHASE INDUSTRIAL DRIVE
ARNOLD, MISSOURI 63010

PHONE: (636) 282-0011
FAX: (636) 282-2722

WEBSITE:
WWW.GENESIS-INTERNATIONAL.COM

EMAIL:
MAIL@GENESIS-INTERNATIONAL.COM