



# GENESIS INTERNATIONAL, INC.

## SHERLOCK 202 NEMA 4X

### REFRIGERANT GAS LEAK MONITORING AND ALARMING SYSTEM



Model#	Nema/ IP Rating	Size Inches(mm)	Electrical Category	Pollution Protection
SHER202-4	4X/ IP67	12.3 x 15 x 8.2 (305 x 356 x 178)	II	3

The SHERLOCK 202 NEMA 4X (SHER202-4) Monitoring System was designed to monitor up to two SHERLOCK Refrigerant Gas Sensors, activating up to two alarms based upon user defined alarm level setpoints. The SHERLOCK 202 is compliant with ASHRAE 15-2004 and Mechanical Code requirements for refrigerant gas monitoring.

**NEMA 4X Enclosure** - This enclosure is intended for either indoor or outdoor use, 0 - 50°C (32 - 122°F), to provide a degree of protection against corrosion, windblown dust and rain, splashing water, and hose directed water.

**Power** Universal Input Power Supply 90 to 250VAC, 50/60 Hz, 2 AMPS

**Inputs** Up to two *Sherlock* Sensors: *Cmos*, *Ir* or One *Sherlock* Sensor and One *Oxygen Deprivation* Sensor

**Outputs** Four (4) SPDT, 250V AC / 30V DC 3.15 Amp Relays.  
Two 12V DC For Audible/Visual  
*Optional Four zone isolation Relays*  
*Optional 4-20mA Analog Signal*

**Setback** 24 Hour Time Clock,  
Two Dry Contact Digital Inputs

**Alarms** 2 Alarm Levels, Two SPDT Relays per Level, Fuse On Common Terminal. One relay on each alarm level can be silenceable when in alarm.

**Operating Environment**  
**Temperature** 35°F - 120°F (2°C - 50°C)  
**Humidity** 0 - 95% RH Non-condensing

**Display** 2 Line By 20 Characters  
Alphanumeric Backlighted LCD display

**Keypad** 5 Tactile Pushbuttons - *Scroll Up*, *Scroll Down*, *Alarm Silent/Clear*, *Select/Edit/Change*, *Exit*

**Alarm Indicators**  
**Display** Name And Current Reading Of Alarming Sensor  
**Buzzer** Built-in Piezo-electric, 90db @10ft, Silenceable  
**Light** Built-in Flashing red Light on the front panel.

**Listings** ETL, Conforms to UL Std. 61010B-1 Certified to CAN/CSA C22.2 Std. No. 1010.1-92

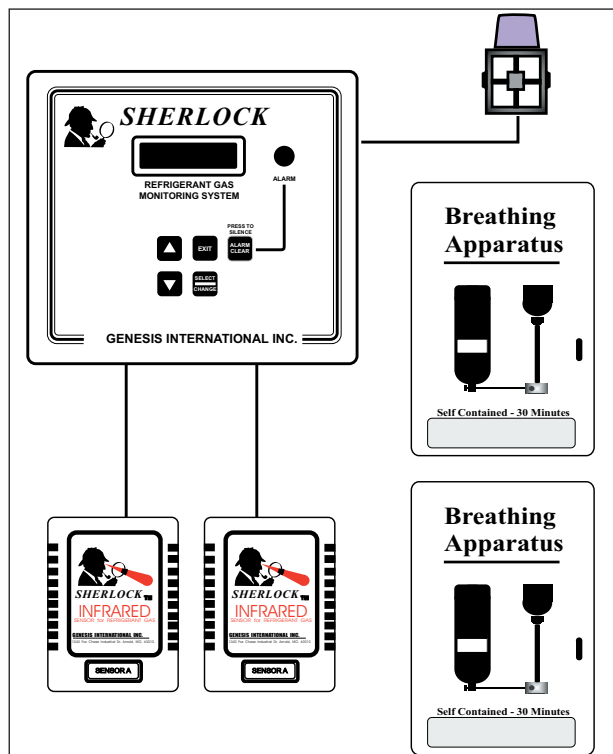

TYPICAL MACHINE ROOM INSTALLATION

**Alarm Level Settings** - The **SHERLOCK 202** allows you to set a unique Level 1 and Level 2 Alarm Setpoint and delay for each individual sensor. These relay can be active Normally Open (N.O.) or Normally Closed (N.C.). When an Alarm Setpoint is exceeded for a user set delay, the corresponding alarm relays will activate. Each Alarm Setpoint has a programable Delay of 1 to 120 minutes. The control provides two fused SPDT (Single Pole Double Throw) relay outputs for each alarm level that change state in the event of an alarm condition. Level 1 Alarm activates Relays #1 and #2 (REFR LEAK LEVEL 1, REFR LEAK LEVEL 1 SILENCEABLE). Level 2 Alarm activates Relays #3 and #4 (REFR LEAK LEVEL 2, REFR LEAK LEVEL 2 SILENCEABLE). Relays #2 and #4 can be silenced (returned to non-alarm state), when the ALARM CLEAR button on the front panel is pushed. Relays #1 and #3 remain active until the alarm condition is cleared. The Control can be programmed so the alarm can be cleared automatically (UNLATCHED) or remain on until manually reset (LATCHED).

**Systems Sensor Open Monitoring** - The **SHERLOCK 202** constantly monitors the wiring to the sensors. Should any of the activated sensor wires be cut or disconnected, "SENSOR ALARM" will appear on the **SHERLOCK** display, the #1 (REFR LEAK LEVEL 1) and #2 (REFR LEAK LEVEL 1 SILENCEABLE) relays will be activated and the condition is logged.

**Alarm Logging** - Alarms are logged to indicate which sensor went in alarm and when for any of the two alarm levels. The alarm log stores the last 10 alarms. When an alarm occurs, the red alarm light on the panel will flash and an on-board beeper will sound. The display will state the alarm condition.

**Setback Alarm Settings** - In some locations the sensor may be expected to function in two different environments. The **SHERLOCK 202** provides a feature called **SETBACK** to accommodate alternative conditions. **SETBACK** provides a secondary **ALARM SETPOINT** and **DELAY**. The control switches to the setback parameters when a dry contact (i.e. air flow switch, sail switch or timer switch) closes or on a daily time schedule.

**Zone Isolation Relays (SHER202-4-R, Factory Installed Option)** - Optional zone isolation alarm relay (#5 SENSOR A ZONE, #6 SENSOR A ZONE SILENCE-ABLE, #7 SENSOR B ZONE, #8 SENSOR B ZONE SILENCE-ABLE). Each relay can be programmed to activate by level 1 or level 1 & 2 alarm. One relay is silenceable and one is non-silenceable.

**Analog Signal Generator (SHER202-4-A, Factory Installed Option)** - The **SHERLOCK 202** has an optional 4-20 mA analog output generator for each sensor which can be incorporated to any commercially used monitoring and alarming system or in-house Data Management System.

### TYPICAL WIRING DIAGRAM

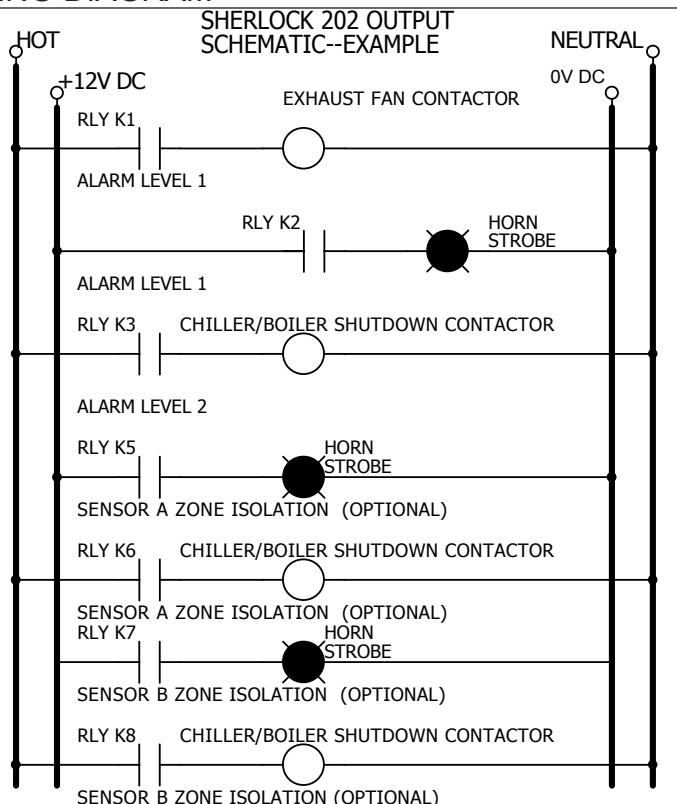
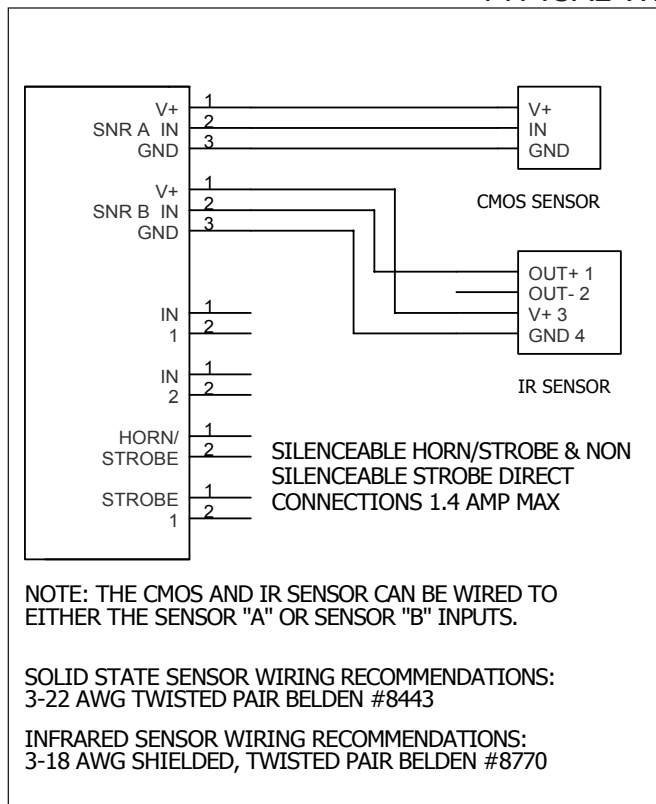

# GENESIS INTERNATIONAL, INC.

1040 FOX CHASE INDUSTRIAL DRIVE  
ARNOLD, MISSOURI 63010

PHONE: (636) 282-0011  
FAX: (636) 282-2722

WEBSITE:  
WWW.GENESIS-INTERNATIONAL.COM

EMAIL:  
MAIL@GENESIS-INTERNATIONAL.COM