



GENESIS INTERNATIONAL, INC.

SHERLOCK 402

REFRIGERANT GAS LEAK MONITORING AND ALARMING SYSTEM



The **SHERLOCK 402 (SHER402) Monitoring System** was designed to monitor up to four SHERLOCK Refrigerant Gas Sensors, activating up to two alarms based upon user defined alarm level setpoints. The SHERLOCK 402 is compliant with ASHRAE 15-2004 and Mechanical Code requirements for refrigerant gas monitoring.

NEMA 1 Compliant Enclosure - This enclosure is intended for indoor use only primarily to provide a degree of protection against contact with the enclosed equipment. The enclosure is not designed to provide protection from water or to be placed in a hazardous environment. Mount only in Pollution Level 2 environments, ie. environmentally controlled offices, control rooms, or environmentally controlled machine rooms.

Model #	Nema/IP Rating	Size Inches (mm)	Electrical Category	Pollution Protection
SHER402	1	12 x 9.5 x 5 (305 x 241 x 127)	II	2

- Power Input** 120/208/240vac, 50/60 Hz, 2.5 Amp
- Inputs** Up to 4 *Sherlock* Sensors: *Cmos, Ir*
or
Up to three *Sherlock* Sensors and One *Oxygen Deprivation* Sensor
- Outputs** Four (4) SPDT, 250V AC / 30V DC, 3.15 Amp Relays and Optional Four (4) more zone isolation alarm Relays
- Setback** 24 Hour Time Clock
Two Dry Contact Digital Inputs
- Alarms** Two Alarm Levels, Two SPDT Relays per Level, Fuse On Common terminal. One relay on each alarm level can be silenceable when in alarm. Optional zone isolation alarm relay for each sensor.

- Operating Environment**
 - Temperature** 35°F To 120°F (2°C To 50°C)
 - Humidity** 0 To 95% RH Non-condensing
- Display** 2 Line By 20 Characters
Alphanumeric Backlighted LCD display
- Keypad** 5 Tactile Pushbuttons
Scroll Up, Scroll Down, Alarm Silent/Clear, Select/Edit/Change, Exit Function-Menu
- Alarm Indicators**
 - Display** Name And Current Reading Of Alarming Sensor
 - Buzzer** Built-in Piezo-electric, 90db @10ft, Silenceable
 - Optional** Strobe Light, Factory Mounted on Top of Unit
- Listings** ETL, Conforms to UL Std. 3111-1
CAN/CSA C22.2 Std. No. 1010.1

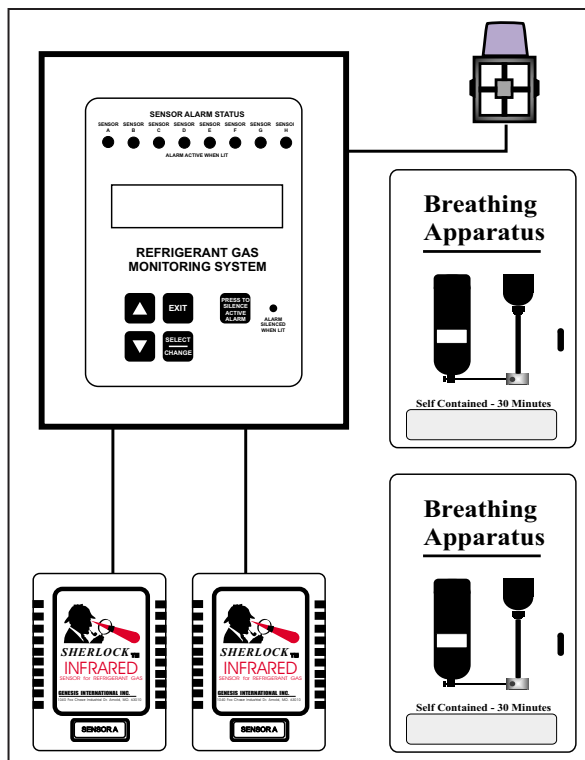

TYPICAL MACHINE ROOM INSTALLATION

Alarm Level Settings - The **SHERLOCK 402** allows you to set a unique Level 1 and Level 2 Alarm Setpoint for up to 4 sensors. When an Alarm Setpoint is exceeded, alarm relays activate. Each alarm setpoint has a programmable Delay of 0 to 120 minutes. Sensor readings are required to exceed an Alarm Setpoint for the programmed amount of time before the control activates the corresponding alarm relay contacts.

Alarm Relay Contacts - The **SHERLOCK 402** provides two fused SPDT (Single Pole Double Throw) relay outputs for each alarm level that switch positions in the event of an alarm condition. Level 1 Alarm activates K1A and K1B relays. Level 2 Alarm activates K2A and K2B relays. Level 2 for each individual sensor can be disabled. Relays K1B and K2B can be silenced (returned to non-alarm state) when the SILENT button on the front panel is pushed. The other alarm relays will remain active until the alarm condition is cleared. The control can be programmed so the alarm is cleared automatically when the sensor goes below the alarm setpoint (UNLATCHED) or stay on until the alarm is manually reset (LATCHED). The K1/K2 alarm level can be configured so the relays are "Energized to Alarm" or "De-Energized to Alarm", Common-Normally Open (C-NO) or Common-Normally Closed (C-NC).

Alarm Indication - Alarms are logged to indicate which sensor went in and out of alarm and when. The alarm log stores the last 32 alarms. When a sensor is in alarm, an LED for this sensor on the front panel will light, the on-board beeper will sound and the display will show the activated alarm level.

Systems Sensor Opening Monitoring - The **SHERLOCK 402** constantly monitors the wiring to the sensors. If any sensor loses communication for any reason, "OPEN" will appear on the display, the alarms will activate and the condition logged.

Setback Alarm Settings - In some instances the control may be expected to function in two different environments. The **SHERLOCK 402** provides a feature called SETBACK to accommodate alternate alarm conditions. SETBACK provides a secondary Alarm Setpoint and Delay. The control changes to the setback parameters when a dry contact closes (i.e. air flow switch, sail switch or timer switch) or on a daily schedule.

Zone Isolation Alarm Relays (SHER402-R, Factory Installed Option) - Optional zone isolation alarm relays (#5 SENSOR A ZONE, #6 SENSOR B ZONE, #7 SENSOR C ZONE, #8 SENSOR D ZONE). Each relay can be programmed to activate by level 1 or level 1 & 2 alarm.

TYPICAL WIRING DIAGRAM

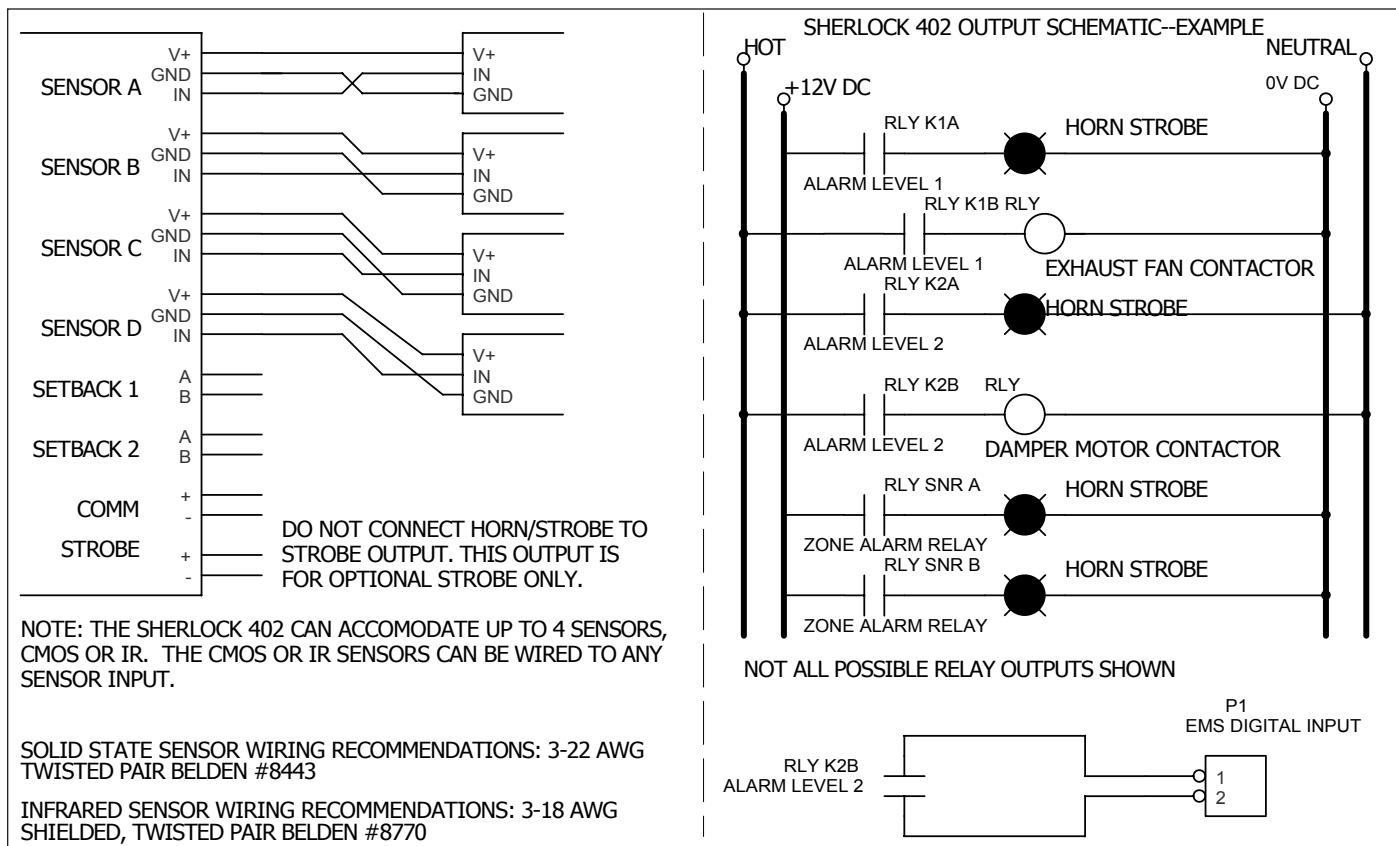

GENESIS INTERNATIONAL, INC.

1040 FOX CHASE INDUSTRIAL DRIVE
ARNOLD, MISSOURI 63010

PHONE: (636) 282-0011
FAX: (636) 282-2722

WEBSITE:
WWW.GENESIS-INTERNATIONAL.COM

EMAIL:
MAIL@GENESIS-INTERNATIONAL.COM