



# GENESIS INTERNATIONAL, INC.

## SHERLOCK 802 NEMA 4X

### REFRIGERANT GAS LEAK MONITORING AND ALARMING SYSTEM



The **SHERLOCK 802 NEMA 4X (SHER802-4) Monitoring System** with optional NEMA 4X Housing was designed to monitor up to eight SHERLOCK Refrigerant Gas Sensors, activating up to two alarms based upon user defined alarm level setpoints. The SHERLOCK 802 is compliant with ASHRAE 15-2004 and Mechanical Code requirements for refrigerant gas monitoring.

**NEMA 4X Enclosure** - This enclosure is intended for either indoor or outdoor use, 0 - 50°C (32 - 122°F), to provide a degree of protection against corrosion, windblown dust and rain, splashing water, and hose directed water.

- Power Input** 120/208/240vac, 50/60 Hz, 2.5 Amp
- Inputs** Upto eight *Sherlock* Sensors: *Cmos*, *Ir* or  
Up to seven *Sherlock* Sensors and One *Oxygen Deprivation* Sensor
- Outputs** Four (4) SPDT, 250V AC / 30V DC, 3.15 Amp Relays and Optional Eight (8) more zone isolation alarm Relays
- Setback** 24 Hour Time Clock  
Two Dry Contact Digital Inputs
- Alarms** Two Alarm Levels, Two SPDT Relay per Level, Fuse On Common Terminal. One relay on each alarm level can be silence able when in alarm. Optional zone isolation alarm relay for each sensor.

<u>Model #</u>	<u>Nema/IP Rating</u>	<u>Size Inches(mm)</u>	<u>Electrical Category</u>	<u>Pollution Protection</u>
SHER802-4	4X	12.3x15.0x8.2	II	3
	IP67	(312x381x208)		

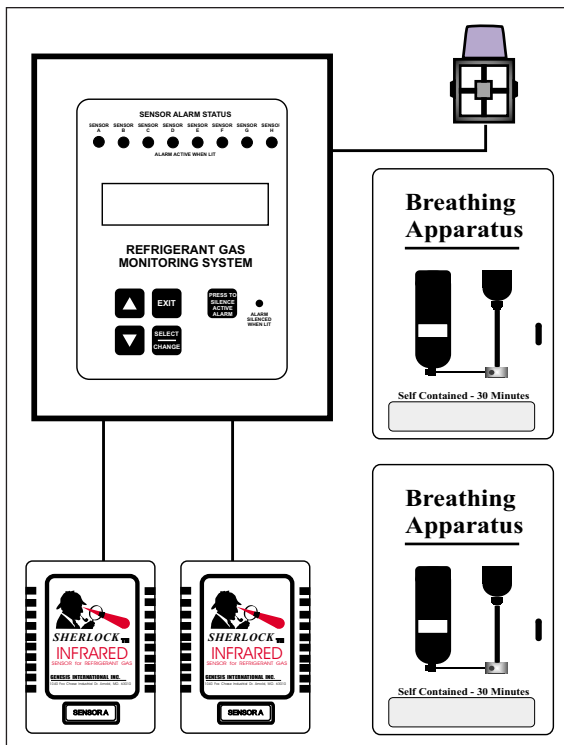

TYPICAL MACHINE ROOM INSTALLATION

- Operating Environment**
  - Temperature** 35°F To 120°F (2°C To 50°C)
  - Humidity** 0 To 95% RH Non-condensing
- Display** 2 Line By 20 Characters  
Alphanumeric Backlighted LCD display
- Keypad** 5 Tactile Pushbuttons  
*Scroll Up, Scroll Down, Alarm Silent/Clear, Select/Edit/Change, Exit Function-Menu*
- Alarm Indicators**
  - Display** Name And Current Reading Of Alarming Sensor
  - Buzzer** Built-in Piezo-electric, 90db @10ft, Silenceable
  - Optional** Strobe Light, Factory Mounted on Top of Unit
- Listings** ETL, Conforms to UL Std. 3111-1  
Certified to CAN/CSA C22.2 Std. No. 1010.1

**Alarm Level Settings** - The **SHERLOCK 802** allows you to set a unique Level 1 and Level 2 Alarm Setpoint for up to 8 sensors. When an Alarm Setpoint is exceeded, alarm relays activate. Each alarm setpoint has a programmable Delay of 0 to 120 minutes. Sensor readings are required to exceed an Alarm Setpoint for the programmed amount of time before the control activates the corresponding alarm relay contacts.

**Alarm Relay Contacts** - The **SHERLOCK 802** provides two fused SPDT (Single Pole Double Throw) relay outputs for each alarm level that switch positions in the event of an alarm condition. Level 1 Alarm activates K1A and K1B relays. Level 2 Alarm activates K2A and K2B relays. Level 2 for each individual sensor can be disabled. Relays K1B and K2B can be silenced (returned to non-alarm state) when the **SILENT** button on the front panel is pushed. The other alarm relays will remain active until the alarm condition is cleared. The control can be programmed so the alarm is cleared automatically when the sensor goes below the alarm setpoint (**UNLATCHED**) or stay on until the alarm is manually reset (**LATCHED**). The K1/K2 alarm level can be configured so the relays are "Energized to Alarm" or "De-Energized to Alarm", Common-Normally Open (C-NO) or Common-Normally Closed (C-NC).

**Alarm Indication** - Alarms are logged to indicate which sensor went in and out of alarm and when. The alarm log stores the last 32 alarms. When a sensor is in alarm, an LED for this sensor on the front panel will light, the on-board beeper will sound and the display will show the activated alarm level.

**Systems Sensor Opening Monitoring** - The **SHERLOCK 802** constantly monitors the wiring to the sensors. If any sensor loses communication for any reason, "OPEN" will appear on the display, the alarms will activate and the condition logged.

**Setback Alarm Settings** - In some instances the control may be expected to function in two different environments. The **SHERLOCK 802** provides a feature called **SETBACK** to accommodate alternate alarm conditions. **SETBACK** provides a secondary Alarm Setpoint and Delay. The control changes to the setback parameters when a dry contact closes (i.e. air flow switch, sail switch or timer switch) or on a daily schedule.

**Zone Isolation Alarm Relays (SHER802-4-R, Factory Installed Option)** - Optional zone isolation alarm relays (#5, SENSOR A ZONE, #6, SENSOR B ZONE, #7, SENSOR C ZONE, #8, SENSOR D ZONE, #9, SENSOR E ZONE, #10, SENSOR F ZONE, #11, SENSOR G ZONE, #12, SENSOR H ZONE). Each relay can be programmed to activate by level 1 or level 1 & 2 alarm.

### TYPICAL WIRING DIAGRAM

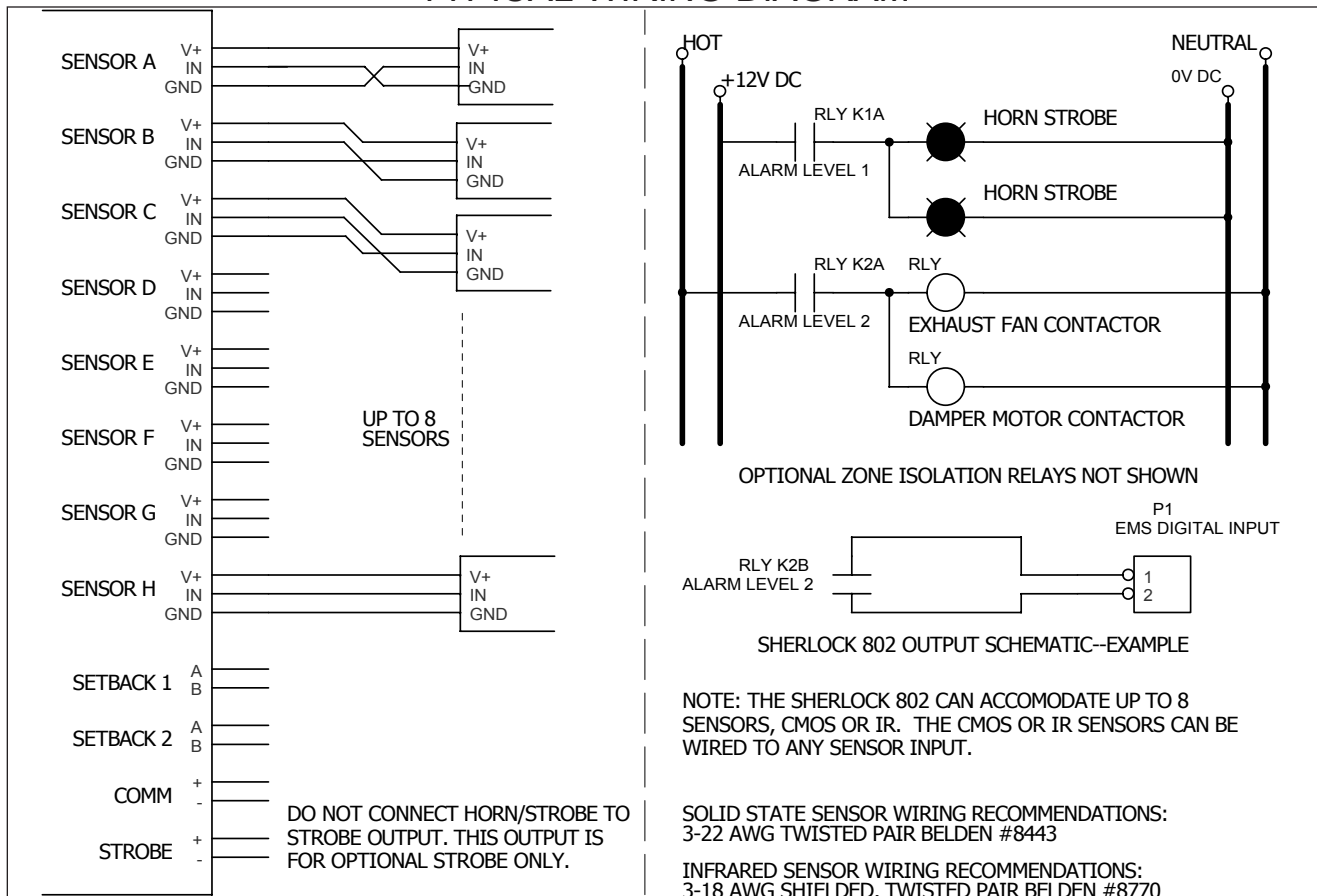

# GENESIS INTERNATIONAL, INC.

1040 FOX CHASE INDUSTRIAL DRIVE  
ARNOLD, MISSOURI 63010

PHONE: (636) 282-0011  
FAX: (636) 282-2722

WEBSITE:  
WWW.GENESIS-INTERNATIONAL.COM

EMAIL:  
MAIL@GENESIS-INTERNATIONAL.COM