

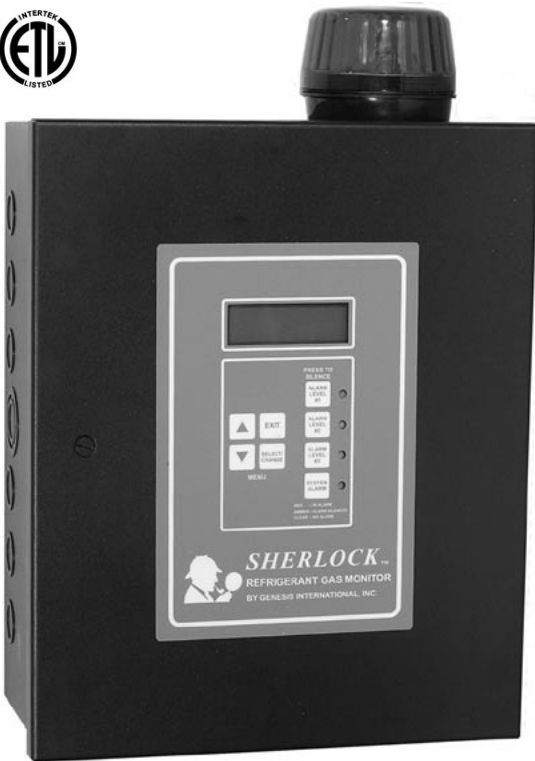

# GENESIS INTERNATIONAL, INC.

## SHERLOCK 404

### CONTROL MODULE



The **SHERLOCK 404** (SHER404) Control Module is compliant with ASHRAE 15-2004 and Mechanical Code requirements for refrigerant gas monitoring.

The **SHERLOCK** is a hardwired, electronic control panel that is capable of monitoring the analog output signal of up to four **SHERLOCK** Refrigerant Gas Sensors or **SHERLOCK** Oxygen Depletion Sensors and four digital dry-contact switches. The Control Module can activate eight, with an optional additional eight, Form C SPDT relay contacts based upon the programmed alarm level setpoint levels of each sensor. The **SHERLOCK** Control Module has an optional 0-10VDC/4-20ma Output Signal Generator for DDC monitoring applications. The Control Module can be located in the area to be monitored, or in a separate location, typically outside of the monitored room.

**NEMA 1 Compliant Enclosure** - This enclosure is intended for indoor use only primarily to provide a degree of protection against contact with the enclosed equipment. The enclosure is not designed to provide protection from water or to be placed in a hazardous environment. Mount only in Pollution Level 2 environments, i.e. environmentally controlled offices, control rooms, or environmentally controlled machine rooms.

Model#	Nema/IP Rating	Size Inches (mm)	Electrical Category	Pollution Protection
SHER404	1	12 x 14 x 7 (305 x 356 x 178)	II	2

- POWER** 100 to 240vac, 50/60 hz, 2.5 Amps
- INPUTS** Up to 4 **SHERLOCK** sensors *Cmos, IR, Oxygen*  
Four dry contacts *2 Setbacks, Alarm Silence, Alarm Clear*
- OUTPUTS** Eight SPDT, 1 Form C, Relays  
250V AC, 30V DC, 3.15 Amp Max.  
Optional 4-20Ma/0-10Vdc signal (SHER404-A)  
Optional 4 Auxilliary (Zone cutoff) relays (SHER404-R)
- ALARMS** System fault (2 relays)  
Three alarm levels (2 Relays per level)
- DISPLAY** 4 lines by 20 characters  
Alphanumeric LCD with back light
- KEYPAD** 8 tactile pushbuttons, Scroll up, Scroll down, Select/Edit/Change, Exit Function, Alarm level silence
- ALARM INDICATORS**
  - LCD** Name, description, and current reading of alarming sensor
  - STROBE** Built-in, blue, 60-90 fpm, 100,000 candle power (Stays on for duration of alarm condition)
  - BUZZER** piezo-electric, 90db @10ft (3.05m), silenceable
  - STATUS LED** Four on front panel of control. Indicates alarm level status:
    - Red-active
    - Amber-silenced
    - No light--not in alarm
- LISTINGS** ETL, Conforms to UL Std. 3111-1  
Certified to CAN/CSA, C22.2 Std. No. 1010.1

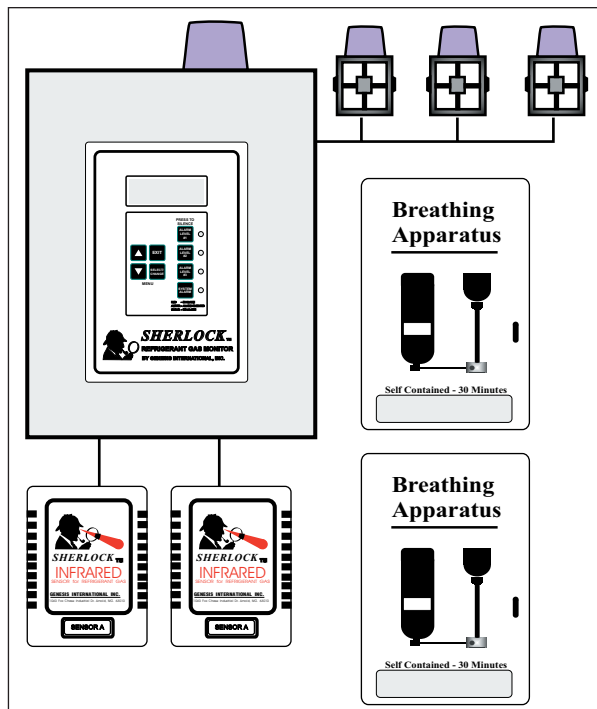

TYPICAL ASHRAE, UMC COMPLIANT MACHINE ROOM INSTALLATION

**Alarm Level Settings** - The *SHERLOCK* 404 allows for three unique **Alarm Setpoints** for each individual sensor throughout the operating range. When an **Alarm Setpoint** is exceeded, a corresponding set of alarm relays activate. Each **Alarm** has a programmable **Delay** of 1 to 120 minutes. Sensor readings must exceed the Setpoint for the delay before the control activates the corresponding alarm relays. Alarm level #1 and Alarm Level #2 on every sensor has the option of using the Time Weighted Average (TWA) reading as the input reading. TWA is the average reading of a sensor input over a period of time.

**Alarm Indication** - All alarms are logged to indicate that a sensor went in and out of any of the three alarm levels and the time and date of the alarm. The log stores the last 32 alarms. When a sensor is in alarm, an LED on the front panel will turn red, the on-board beeper will sound and the display shows "IN ALARM" every five seconds. The individual sensor display causing the alarm also shows the "ALARM" message.

**Alarm Relay Contacts** - The 404 provides two fused SPDT (Single Pole Double Throw) relay outputs for each alarm level that switch positions in the event of an alarm. The 'B' relay for each alarm level can be temporarily or permanently silenced by pushing the respective alarm silence button on the front panel. The relay will re-activate after a programmed period, if the alarm condition is not cleared. The 'A' relay remains active until the alarm condition is cleared. The 404 can be programmed so that the alarm clears automatically when the sensor reading goes below the alarm setpoint (UNLATCHED) or be manually reset (LATCHED). Each alarm level can be configured so the relays are "Energized to Alarm" (where the C-NO contacts close on alarm) or "De-Energized to Alarm" (where

the relay is energized during normal operations and the C-NC contacts close on alarm).

**Systems Fault Monitoring** - In addition to the three alarm levels the control is also equipped with a SYSTEM FAULT ALARM. This alarm is triggered when the system malfunctions (i.e. The sensor wire or inter-connect cable lose connection). The 404 constantly monitors the wiring to each sensor. Should any of the activated sensor wires lose connection, "OPEN" will appear on the SHERLOCK display, the alarm #1 and system alarm are activated and the condition is logged.

**Setback Alarm Settings** - In some locations the sensor may be expected to function in two different environments. The 404 provides a feature called SETBACK to accommodate alternative conditions. SETBACK provides a secondary ALARM SETPOINT and DELAY. The control switches to the setback parameters when a dry contact (i.e. air flow switch, sail switch or timer switch) closes or on a daily time schedule.

**Analog Signal Generator - (SHER404-A)** The 404 has as an option, a 0-5V / 0-10V / 4-20 mA analog output for each sensor factory mounted into the control. These signals can be incorporated to any commercially used monitoring and alarming system or in-house Data Management System. This option is a factory installation but **can** be retrofit in the field if needed.

**Zone Isolation Alarm Relays - (SHER404-R)** The 404 has as an option, an additional zone isolation relay board. Two SPDT relays per sensor will activate only when the specific sensor is in alarm. These relays are in addition to the standard alarm relays and can be set to alarm at any level. This option is a factory installation and **cannot** be retrofit in the field.

### TYPICAL WIRING DIAGRAM

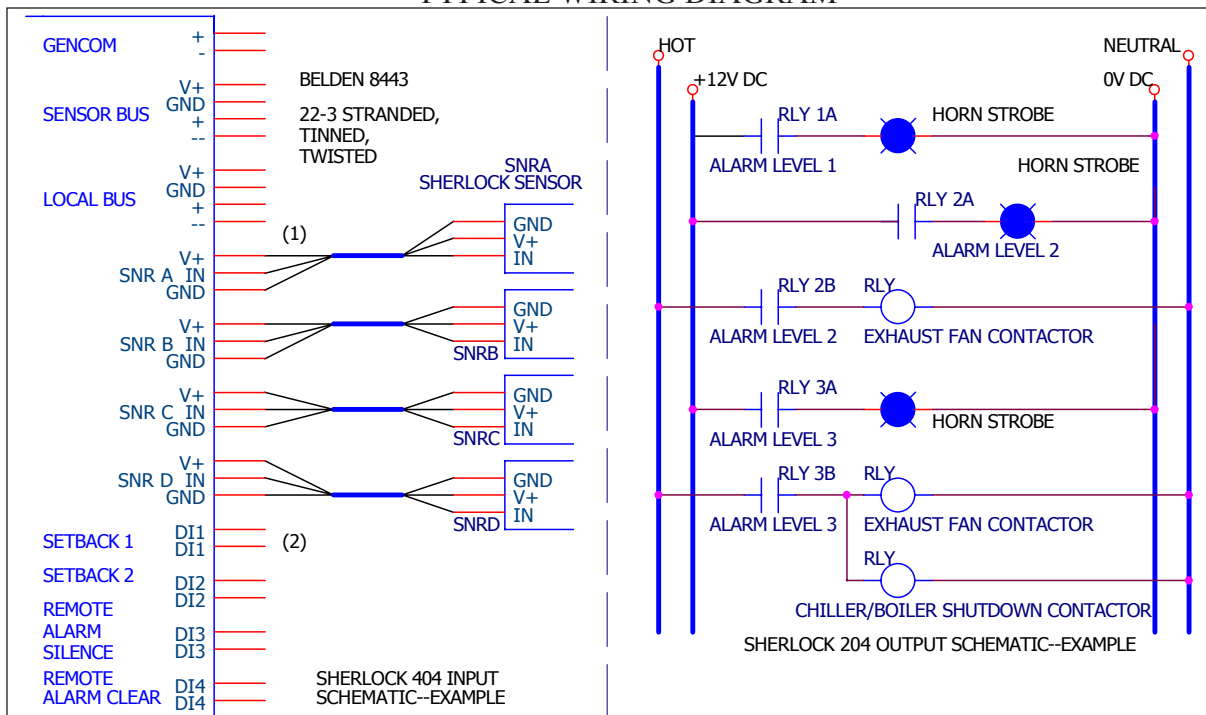

# GENESIS INTERNATIONAL, INC.

1040 FOX CHASE INDUSTRIAL DRIVE  
ARNOLD, MISSOURI 63010

PHONE: (636) 282-0011  
FAX: (636) 282-2722

WEBSITE:  
WWW.GENESIS-INTERNATIONAL.COM

EMAIL:  
MAIL@GENESIS-INTERNATIONAL.COM